

Buoyancy-Induced Columnar Vortices for Power Generation

A proposal for the utilization of updraft systems to sustainably generate electrical power, reduce global warming and increase localised rainfall

Presentation by

Donald Cooper MIEAust

Photo: University of Wisconsin - Milwaukee

Roberto Giudici

Incoming solar radiation

Infrared radiation to Space

Convection

Water vapour and warm air

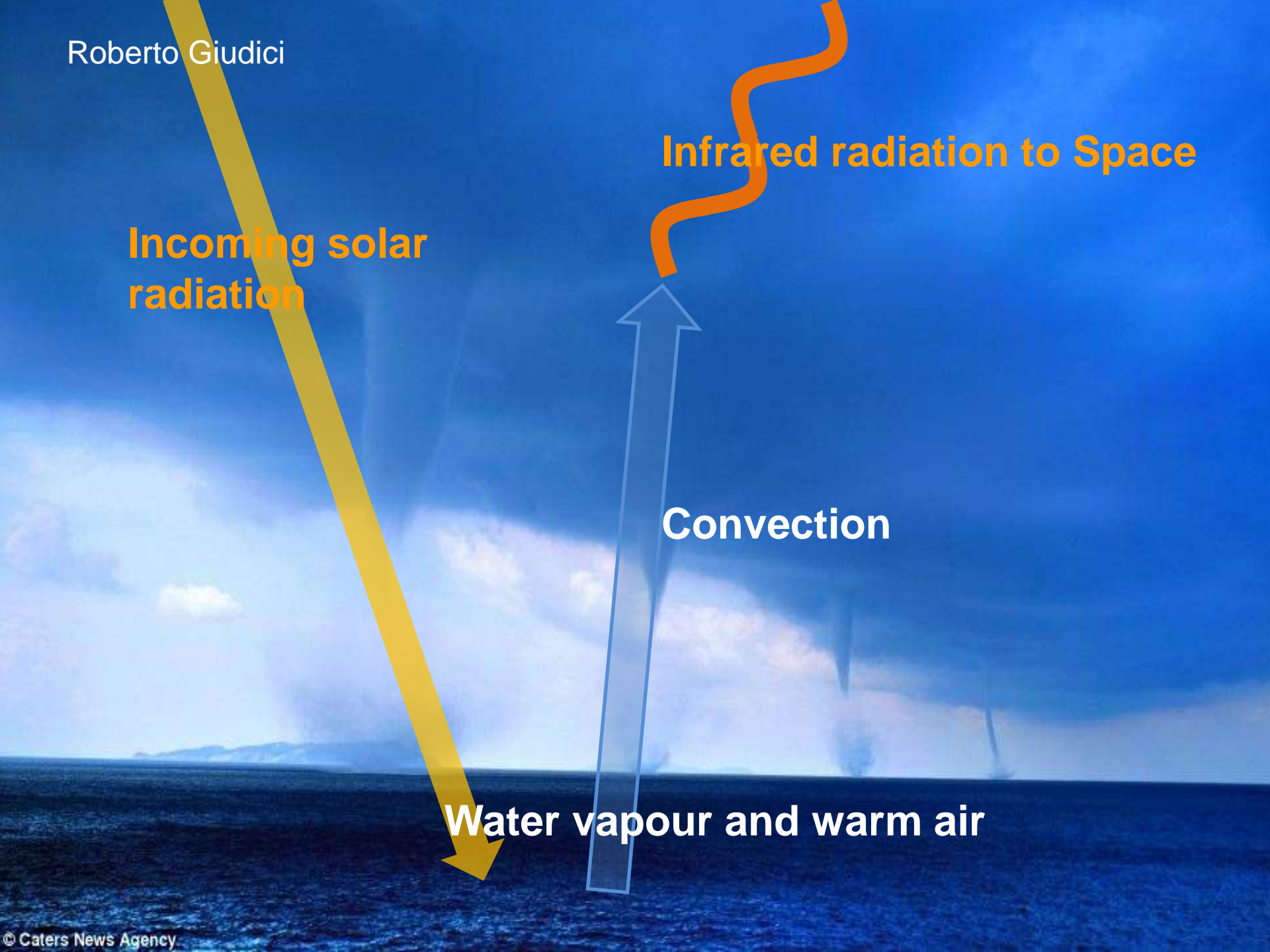

Seeing just one waterspout is thought by many to be a once-in-a-lifetime event, but one lucky boat passenger managed to capture four in these amazing pictures.

Italian Roberto Giudici managed to take the pictures while sailing off the Greek Island of Orthoni, in the Ionian Sea, when a huge storm blew up over night.

The morning light then revealed this stunning scene of the four waterspouts, which develop in a similar way to tornadoes but are usually weaker.



Background: Latent Heat in Atmospheric Water Vapour is Released Within a Buoyant Plume

The energy required to transform a tonne (roughly one cubic metre) of ice at minus 70°C into vapour at 30°C is around 3.5 Gigajoules.

Conversely, transforming a tonne of water vapour into ice between the same temperature range *liberates* this amount of energy into the environment.

This is comparable to the chemical energy contained in 100 litres of fuel oil. The notional “volumetric ratio” of water vapour to fuel oil is thus in the region of 10:1.

A rising atmospheric plume typically works between 30°C at ground level to minus 70°C at the top of the troposphere. As the water vapour condenses and eventually freezes, energy is released. This warms the surrounding air, resulting in an increase in the buoyancy and hence the corresponding potential energy of the air within the plume.

This buoyancy can be utilized to convey the air-water vapour mixture to higher altitude, and in some instances supply excess energy for the production of electrical power as a by-product.

The Energy Content of Atmospheric Water Vapour

It has been estimated that the Earth's atmosphere holds in the region of 12,900 cubic kilometres of water in the form of water vapour

(ref: The Case for Alternative Fresh Water Sources; Dec. 2000).

D Beysens & I Milimouk; Secheresse;

Based on the 10:1 rule of thumb, this then has the energy content equivalent to about 1,200 cubic kilometres of fuel oil, and a significant percentage of this can be sustainably "harvested," mostly for lifting water to an altitude where precipitation can be initiated, radiating heat to Space, but also a significant percentage for non-polluting electrical power generation.

The vortex engine principle, invented independently by Australian physicist Norman Louat and Canadian engineer Louis Michaud is designed to achieve these aims.

Time for Replenishment of Atmospheric Water Vapour

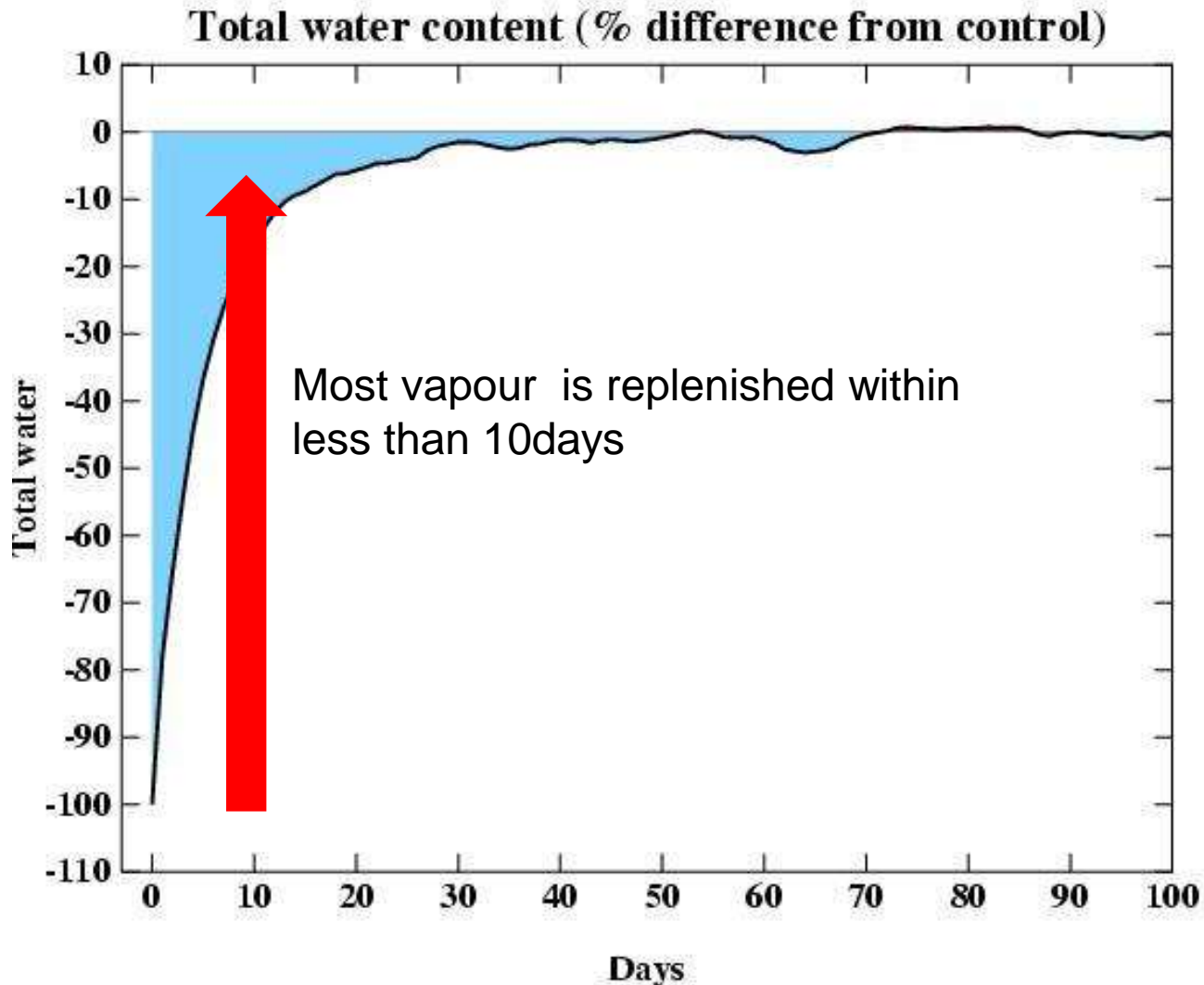

Source: <http://www.realclimate.org/index.php/archives/2005/04/water-vapour-feedback-or-forcing/>

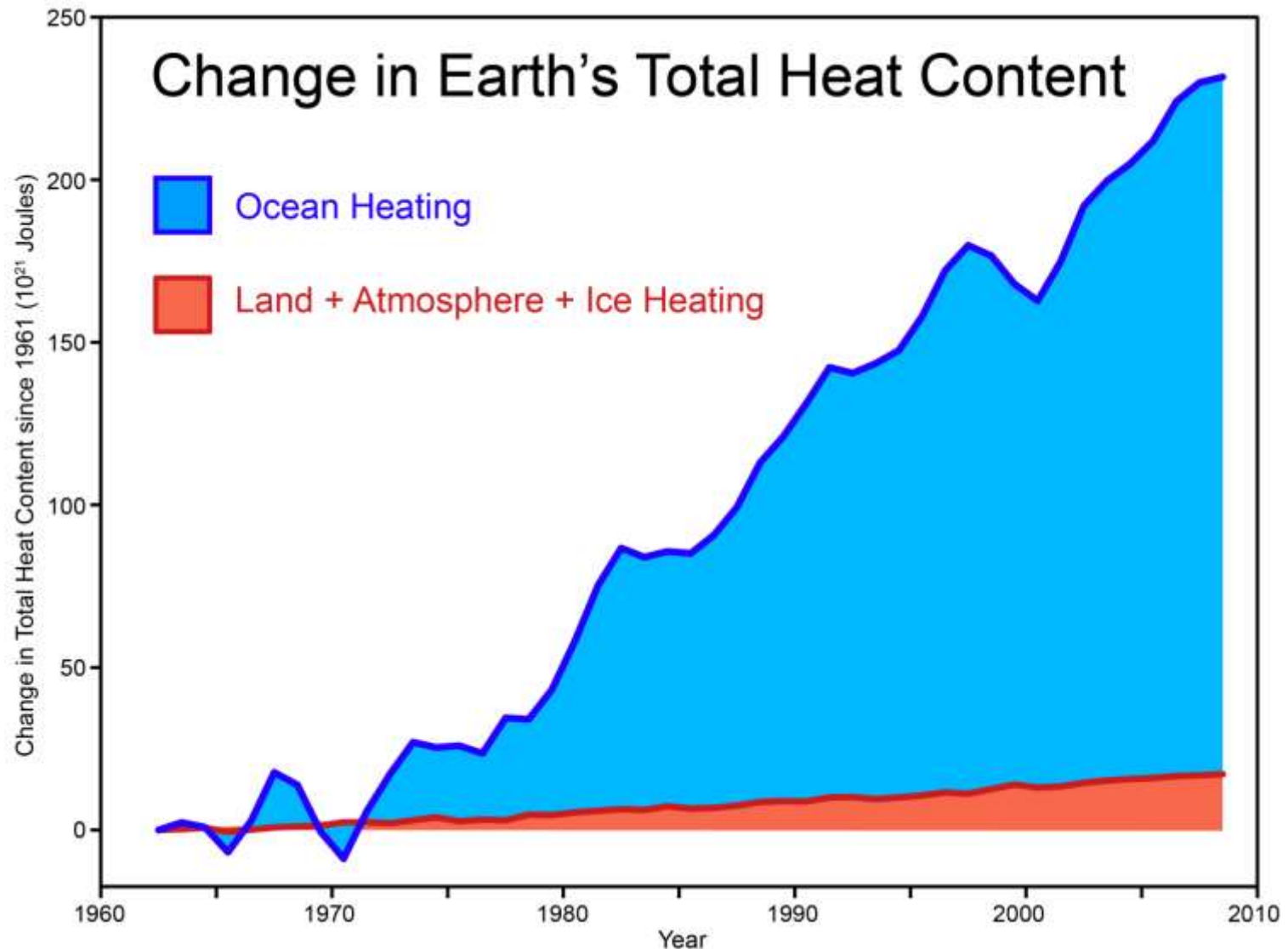

From Nuccitelli et al. (2012), described at skepticalscience.com.

For sustainability, this heat content must be stabilised.

A Comparison of Earth's Stored Energy Resources

Crude Oil Reserves

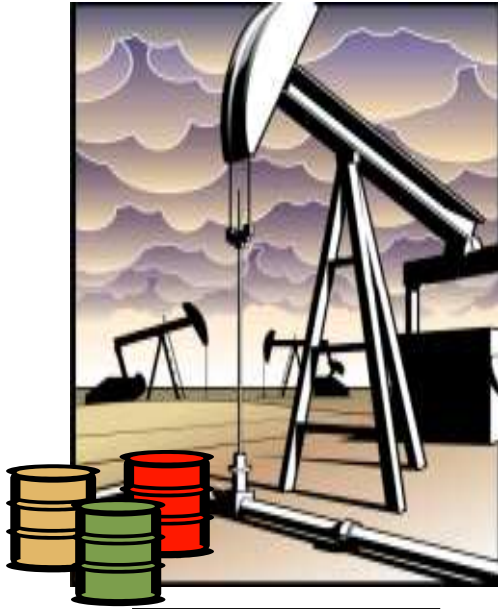

$7.3 \times 10^{21} \text{ J}$



Latent heat of water vapor in the bottom kilometre of the atmosphere

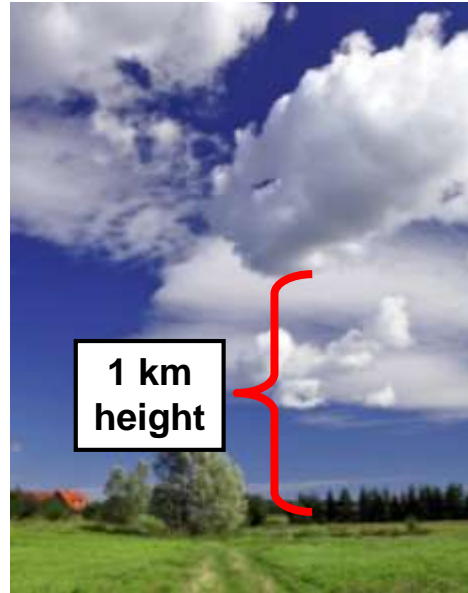

$13 \times 10^{21} \text{ J}$



Heat content of tropical ocean water

100 m layer, 3°C

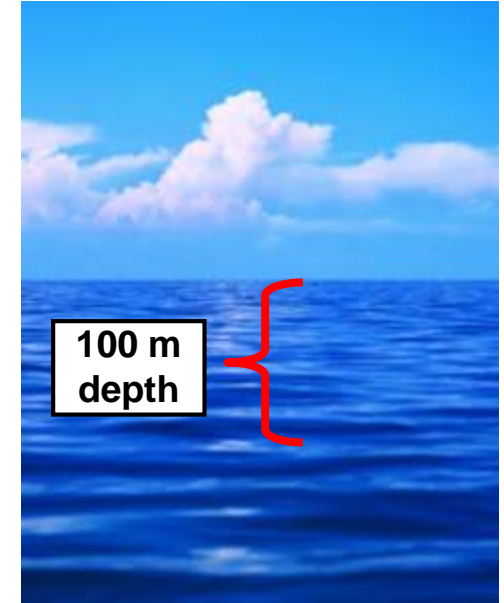

$130 \times 10^{21} \text{ J}$

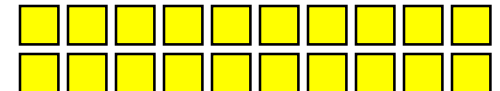

Replenishment times

10^9 years

10 days

Eric Michaud

100 days

Assumptions / Calculations

Crude Oil Reserves

$$1200 \cdot 10^9 \text{ bbl} \quad [1]$$

$$\times 6100 \cdot 10^6 \frac{\text{J}}{\text{bbl}} \quad [2]$$

$$= 7.3 \times 10^{21} \text{ J}$$

[1] World Crude Oil and Natural Gas Reserves, January 1, 2007, Energy Information Administration

[2] Energy Calculator, Energy Information Administration, <http://www.eia.doe.gov>

Latent heat of water vapor in the bottom kilometre of the atmosphere

$$10 \frac{\text{kg}}{\text{m}^2} \quad [3]$$

$$\times 2.5 \cdot 10^6 \frac{\text{J}}{\text{kg}} \quad [4]$$

$$\times 510 \cdot 10^{12} \text{ m}^2 \quad [5]$$

$$= 13 \times 10^{21} \text{ J}$$

[3] Assuming 10 kg/m² average moisture content in the bottom 1 km of the atmosphere

[4] Latent heat of water vapour (*conservative value neglecting the latent heat of fusion*)

[5] Surface area of the Earth

Heat content of tropical ocean water

100 m layer, 3°C

$$1000 \frac{\text{kg}}{\text{m}^3} \times 100 \text{ m} \quad [6],[7]$$

$$\times 4190 \frac{\text{J}}{\text{kg} \cdot \text{K}} \times 3^\circ \text{C} \quad [8],[9]$$

$$\times 510 \cdot 10^{12} \text{ m}^2 \times 20\% \quad [10]$$

$$= 130 \times 10^{21} \text{ J}$$

[6] density of water

[7] Assuming 100 m depth

[8] sensible heat of water

[9] Assuming 3°C

[10] Assuming the area of Earth's tropical oceans = Area of Earth x 20%

The Troposphere

Trópos – Greek for “turning” - mixing

- The troposphere is the lowest of the strata within the atmosphere. It is well mixed by convection, but there are meteorological factors which inhibit the convection process
- An important factor in convection is the release of energy contained within water vapour, principally in the form of latent heat of fusion and vaporization
- **It will be shown that effective convection within the troposphere is crucial for mitigating global warming**

Overview

- Global warming occurs when the incoming solar energy exceeds that being radiated back into Space from the upper atmosphere in the form of infra-red radiation.
- Well over half the outward transmission of energy from the Earth's surface through the troposphere occurs in the form of convection.
- There is often a significant barrier to convection within a “boundary” layer in the lowest two kilometres of the troposphere. This impediment can be reduced by several methods. One of these is arguably the vortex engine.

Three concepts are arguably able to significantly enhance tropospheric convection:

The gravity tower

The solar updraft tower

The vortex engine

First, the Gravity Tower

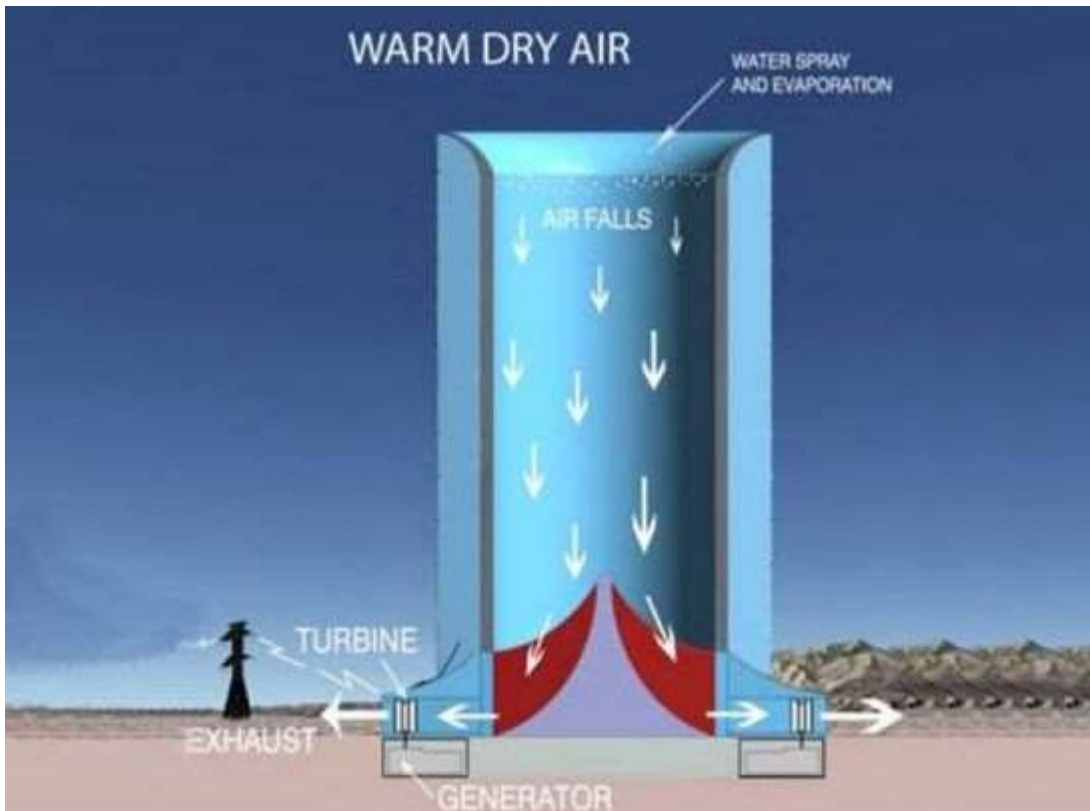

A Solar Wind Energy Tower proposed for Arizona has a design capacity of 450 MW.
(4×10^9 kWhr per annum)

680 m high, 350 m diameter. Projected cost \$1.5 billion.

Second, the Solar Updraft Tower

Solar Chimney



Manzanares
200 m high, 10 m diameter
Collector 0.04 sq. km
50 kw, 130 J/kg, 1 tonne/s
Spain 1982 to 1989

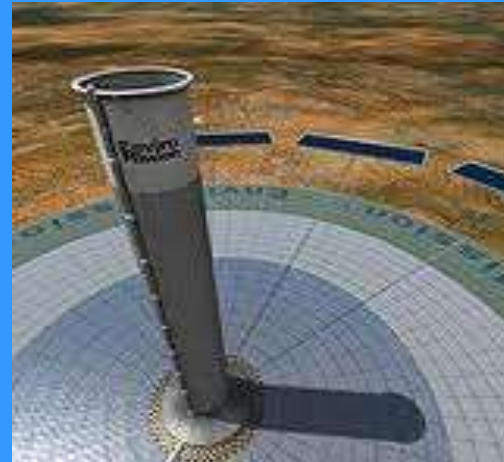

Enviromission
800 m high, 130 m diameter.
Collector ~30 sq km
200 MW, 300 tonne/sec
Australia / US

Enviromission has committed to build a 200 MWe solar-thermal power station, also in Arizona.

800 m high. Projected cost \$750 million.

Press release 1/9/15 - EnviroMission Signs US\$110M Funding Heads of Agreement.

Third, the Vortex Engine

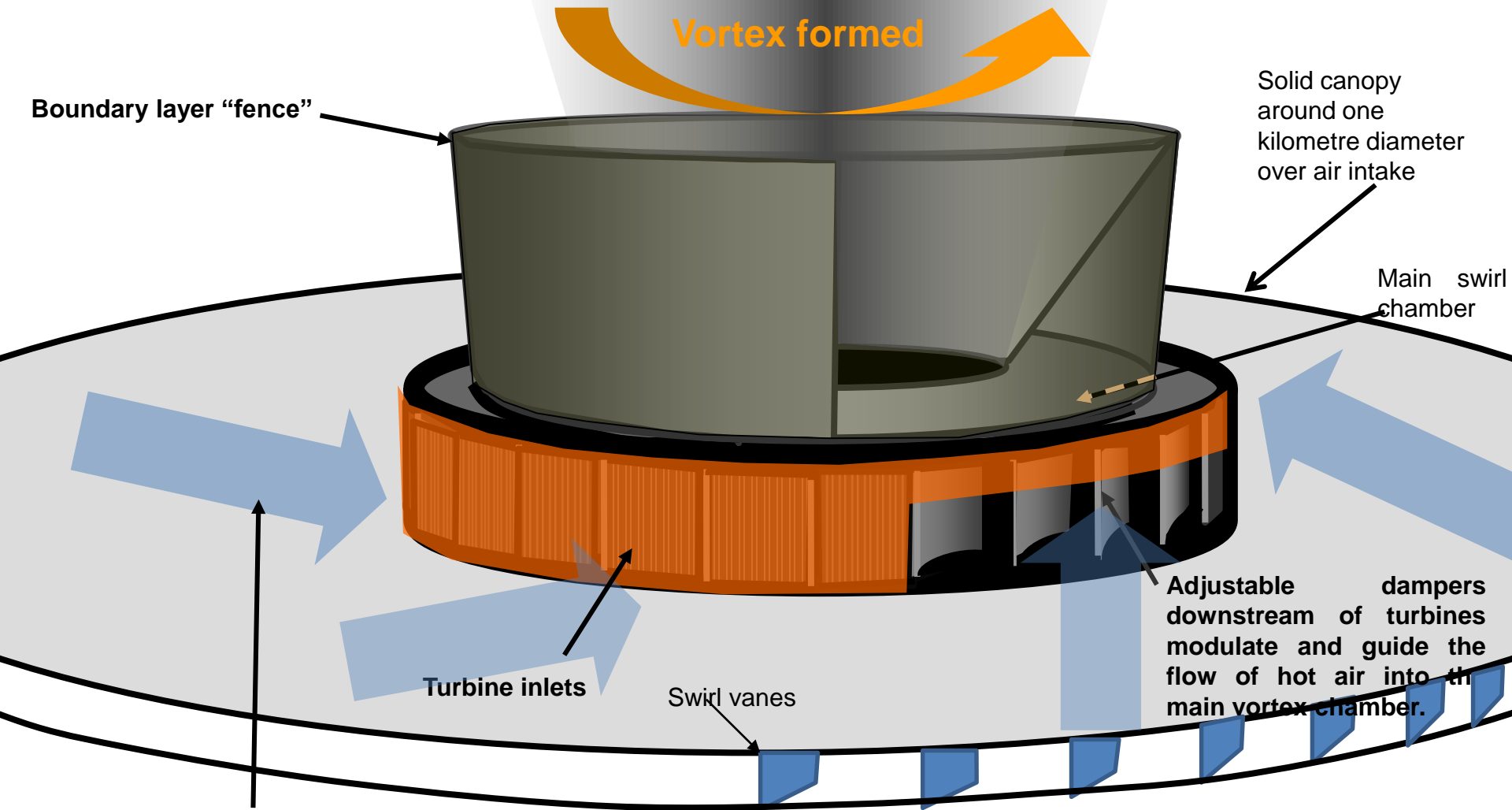

Air picks up heat from pipes beneath a canopy creating a water-to-air heat exchanger, before entering the vortex engine main swirl chamber

The power of the vortex to penetrate the convective inhibition layer

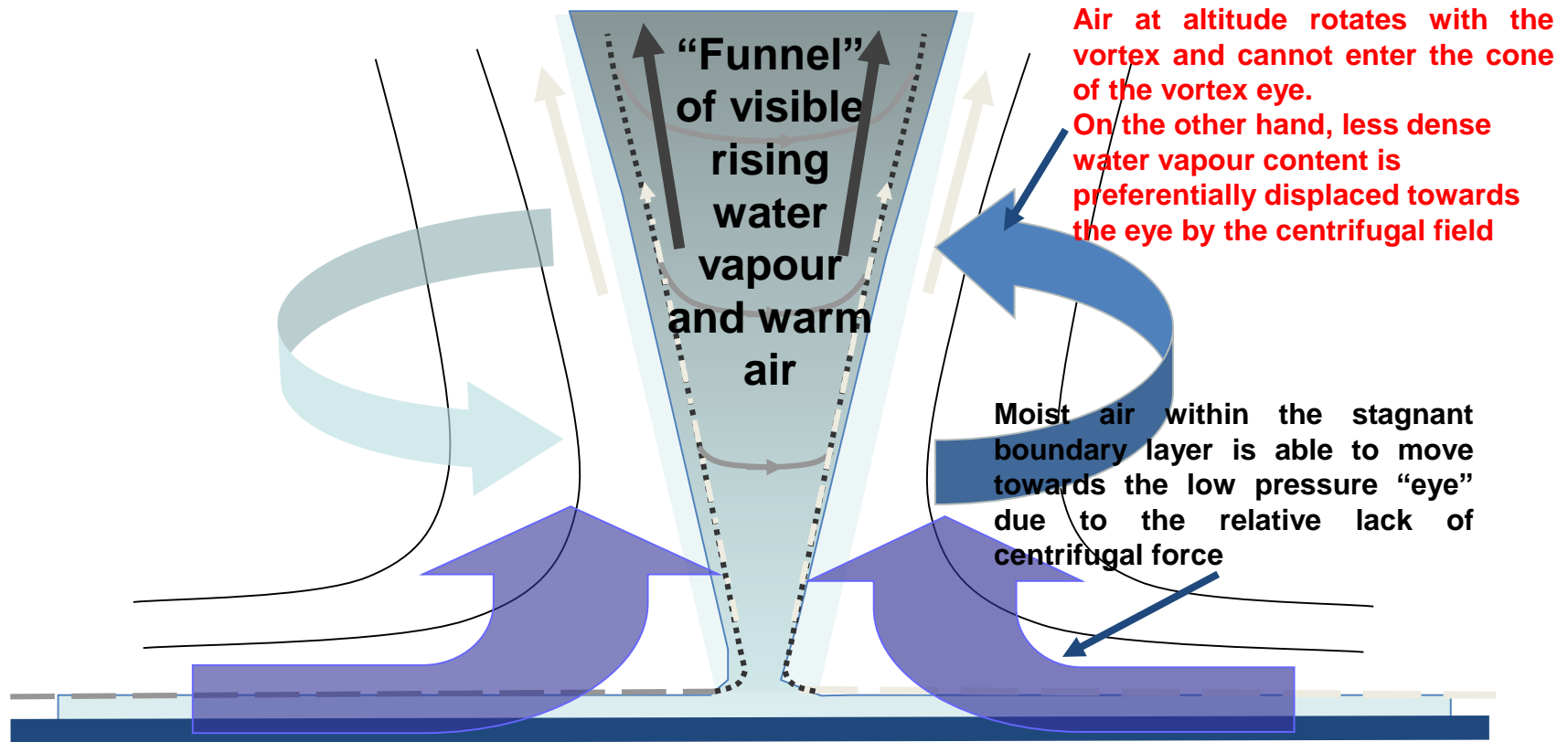

The vortex mechanism **inherently minimizes entrainment** between the highly buoyant updraft stream and the surrounding atmosphere

The mass flowrate of air through the 200 MW vortex engine would be in the region of 30 tonne/s:

Assuming

- 1% water vapour content, the water mass flowrate through the system would be 300 kg/s.
- All the water vapour is converted to ice at -70C at the top of the troposphere the power available is $300 \times 3,500 = 1050$ MW.
- The power available from the sensible heat of the air, based on ΔT of 100C is 30 MW.

Based on an overall plant efficiency of 20%, the output would be around 200 MW.

The height to which a buoyancy vortex persists before breakdown to a turbulent plume will depend on:

- Convective Available Potential Energy (CAPE)
- System scale
- Radiation of heat away from the plume

The CAPE of the gas stream is a function of the internal energy of the convecting fluid. In tornadoes, the latent heat of fusion and evaporation of water vapour are important in this regard. Calculation of CAPE is covered at

http://tornado.sfsu.edu/geosciences/classes/m201/buoyancy/CAPE_Procedure.html



Waterspouts seen from the beach at Kijkduin near The Hague, the Netherlands on 27 August 2006.

Although having a very modest temperature differential with the ambient atmosphere, these vortices are rising 8-10 km through the troposphere

On the other hand, a non-rotating plume has an inherently high level of entrainment

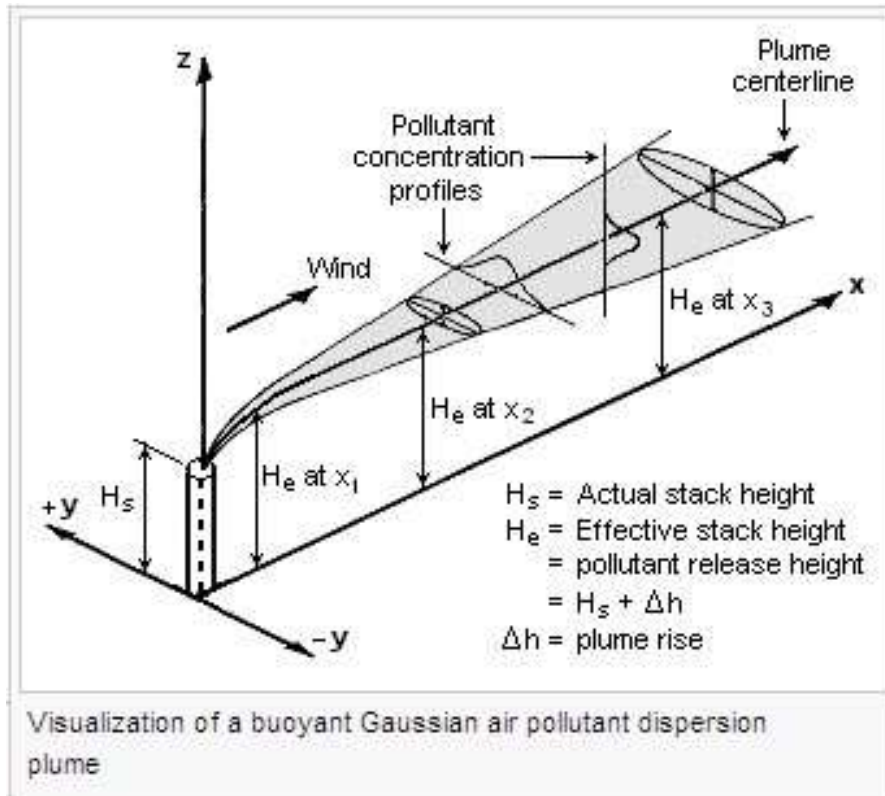

The temperature differential involved is much higher than the waterspouts, but entrainment of the surrounding air severely inhibits convection

The use of enhanced thermal inertia with Solar Updraft Towers and Vortex Engines in order to generate base load (essentially 24 hr/day) power:

Updraft tower – Enhanced thermal inertia

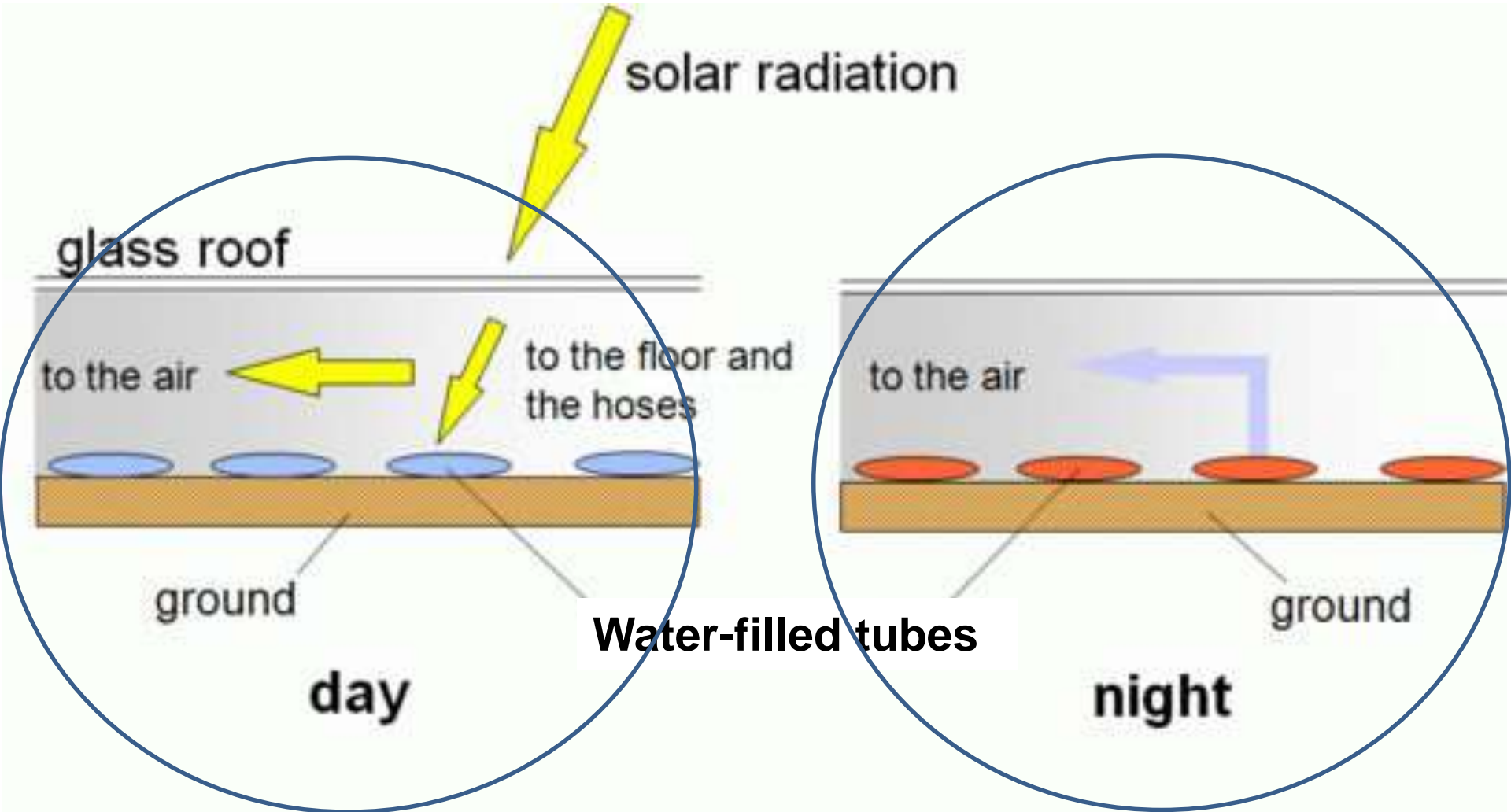

Updraft Tower – enhanced thermal Inertia

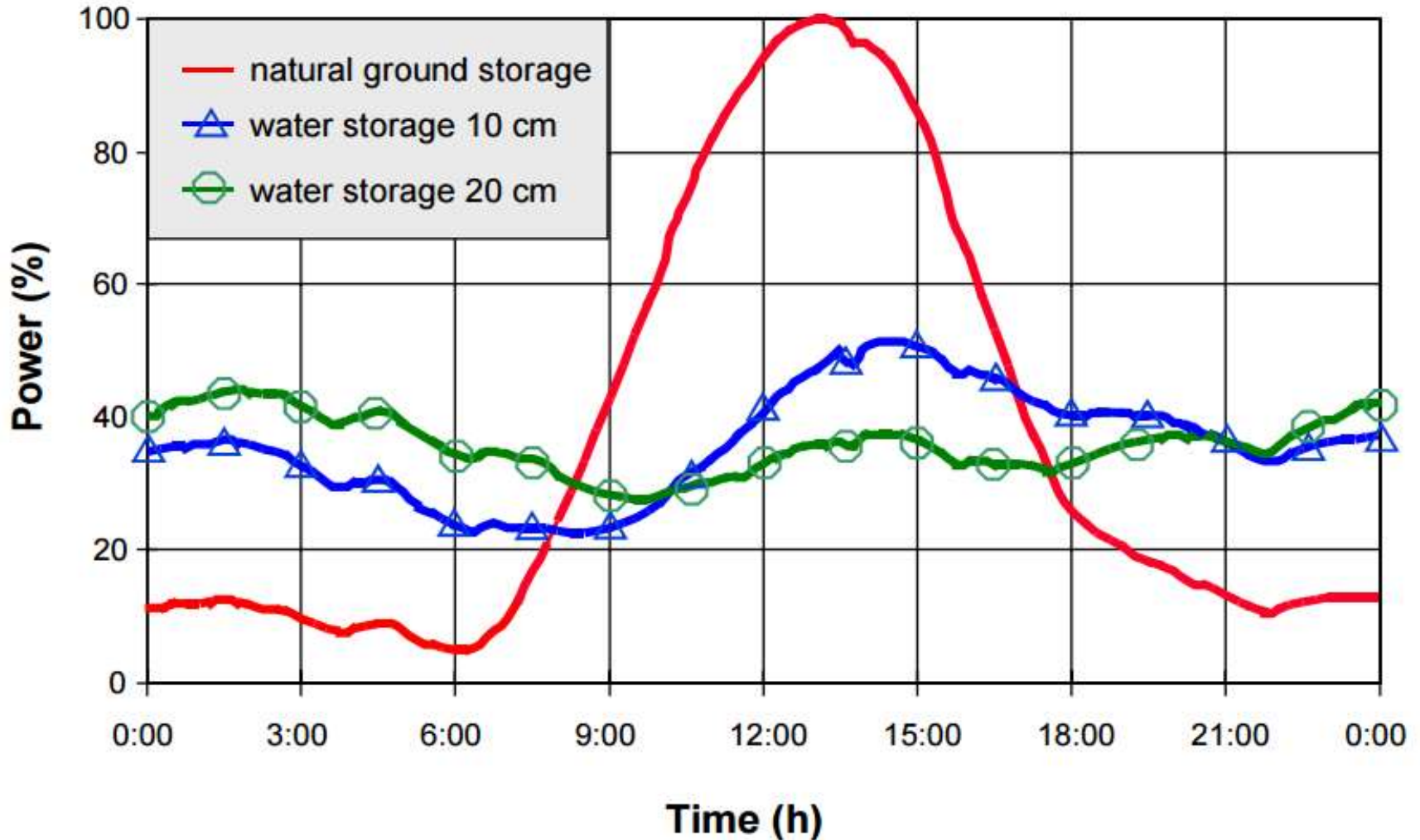

Effect of heat storage underneath the collector roof using water-filled black tubes. Simulation results from (Kreetz, 1997).

Solar updraft tower with water storage **over 25% collector area**

Summer

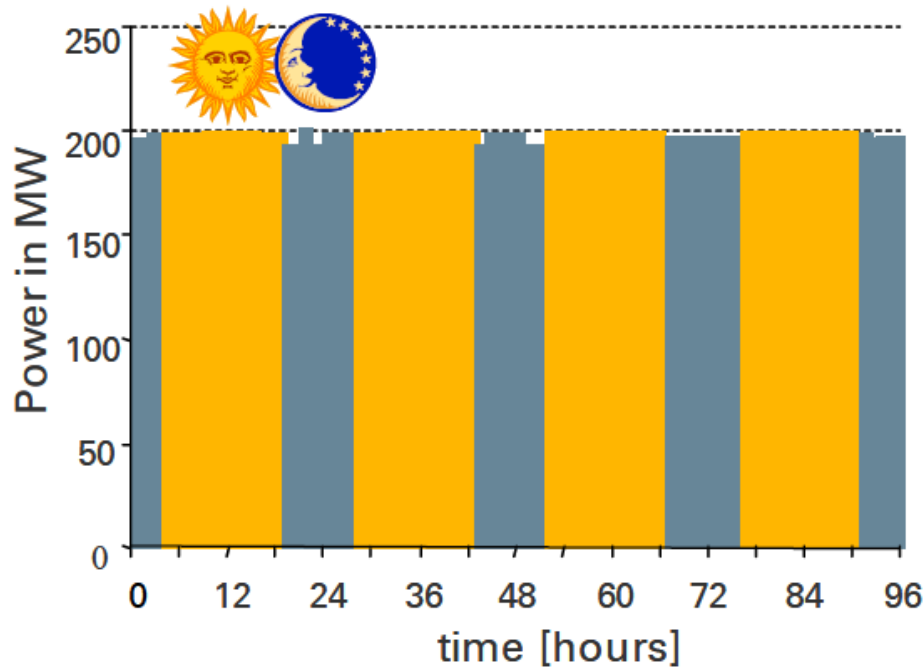

Winter

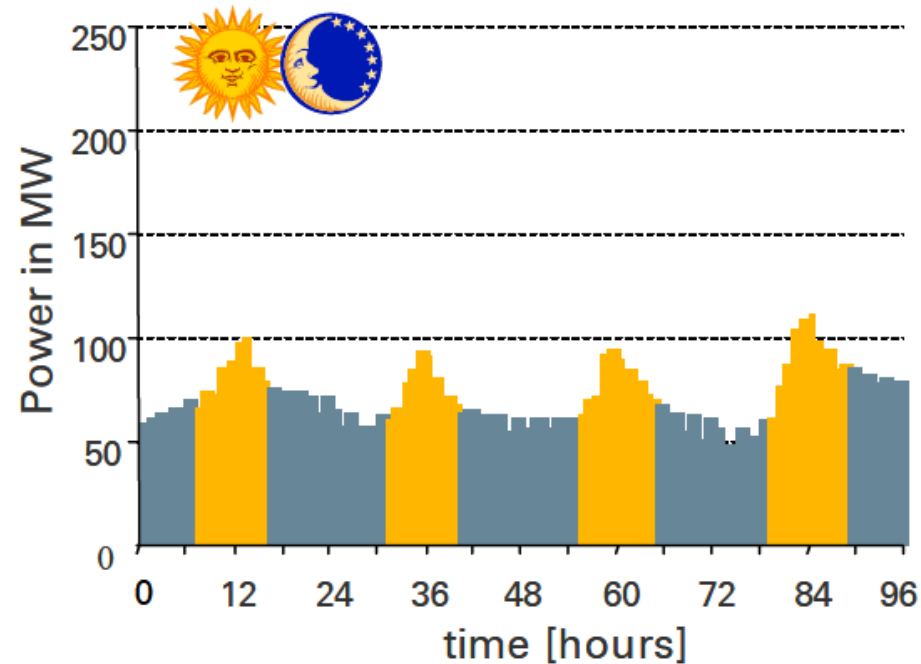

Results of simulation runs (electric power output vs. time of day) of a 200 MW solar tower with 25% of collector area covered by water-filled bags as additional thermal storage (weather data from Meteotest, 1999).

The above graphs relate to Switzerland latitude 47 degrees N.
The hours of sunlight in winter are relatively low.

Sectional diagram of Proposed Vortex Engine

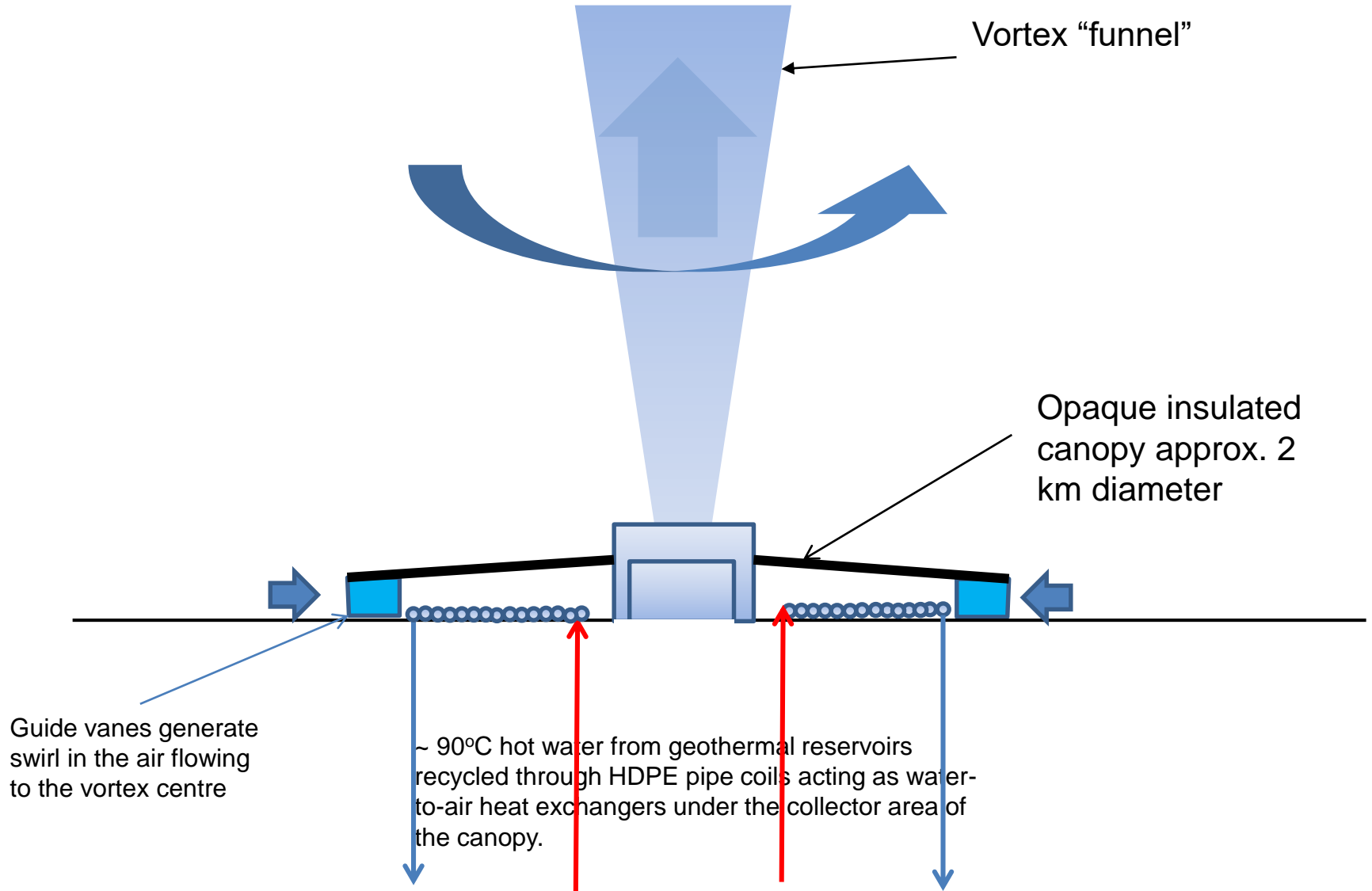

The importance of tropospheric convection for the mitigation of global warming

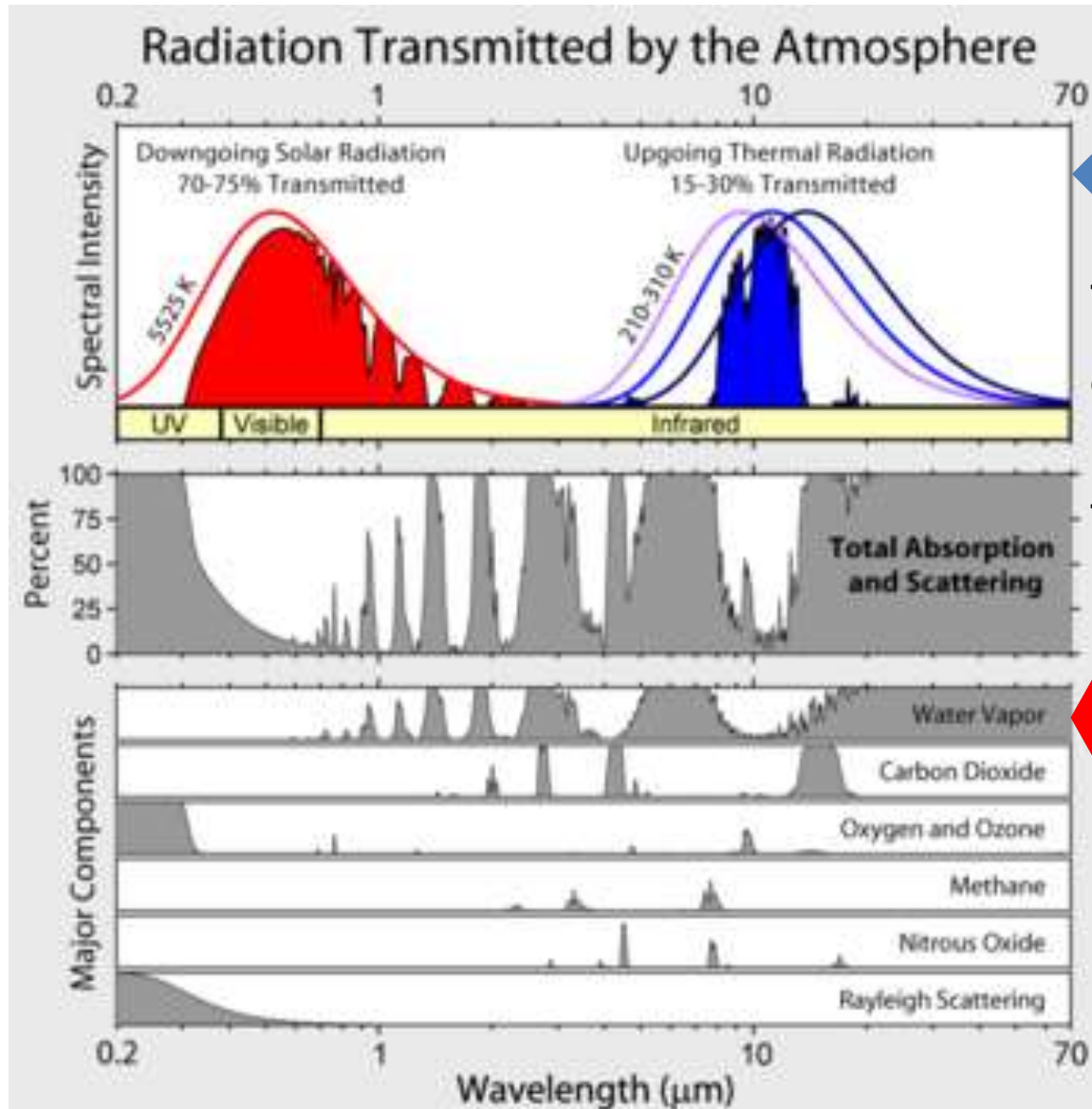

The deficit between downgoing and upgoing radiation **must** be made up for by convection processes



Water vapour is by far the most critical greenhouse gas

The importance of latent heat in convection

- Evaporation/condensation is primary way that energy is transferred from surface to atmosphere:

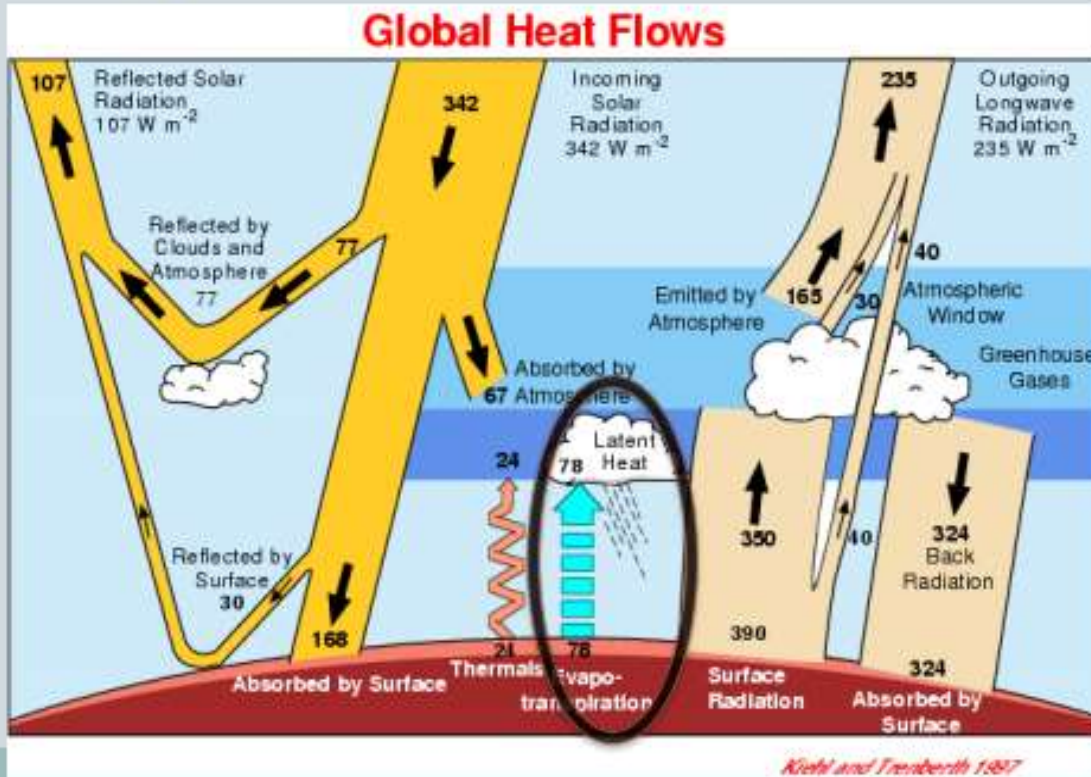

Latent heat flux = 78
 Sensible (thermal)
 heat flux = 24
 Net radiative flux from
 surface to atmos
 $350 - 324 = 26$

Over 60% of heat
 is transferred off
 surface by
 moisture!

http://www.atmos.washington.edu/~dargan/587/587_3.pdf

Convection of water vapour through the troposphere provides by far the most effective single way in which Earth's heat can eventually be re-radiated to Space.

As greenhouse gases such as CO₂ and H₂O increase, so too, must convection processes.

The Earth's surface is the troposphere's "heating element"

"The [atmosphere] is heated from the ground up because the surface of the Earth absorbs energy and heats up faster than the air. The heat is mixed through the troposphere because on average the atmosphere in this layer is slightly unstable."

University Corporation for Atmospheric Research

http://www.windows.ucar.edu/tour/link=/earth/Atmosphere/layers_activity_print.html&edu=high

Problems with natural tropospheric convection

“Study: Warmer World Will Produce Fewer Clouds”

January 03, 2014

<http://www.voanews.com/content/study-warmer-world-will-produce-fewer-louds/1822952.html>

Steven Sherwood, a climate scientist at Australia's Centre of Excellence for Climate System Science and lead author of the report, says the prediction of a 4° Celsius warming is based on the role of water vapour in cloud formation:

“What we see in the observations is that when air picks up water vapour from the ocean surface and rises up, it often only rises a few kilometres before it begins its descent back to the surface,” Sherwood said. “Otherwise it might go up 10 or 15 kilometres. And those shorter trajectories turn out to be crucial to giving us a higher climate sensitivity because of what they do to pull water vapour away from the surface and cause clouds to dissipate as the climate warms up.”

(Emphasis added)

What this means

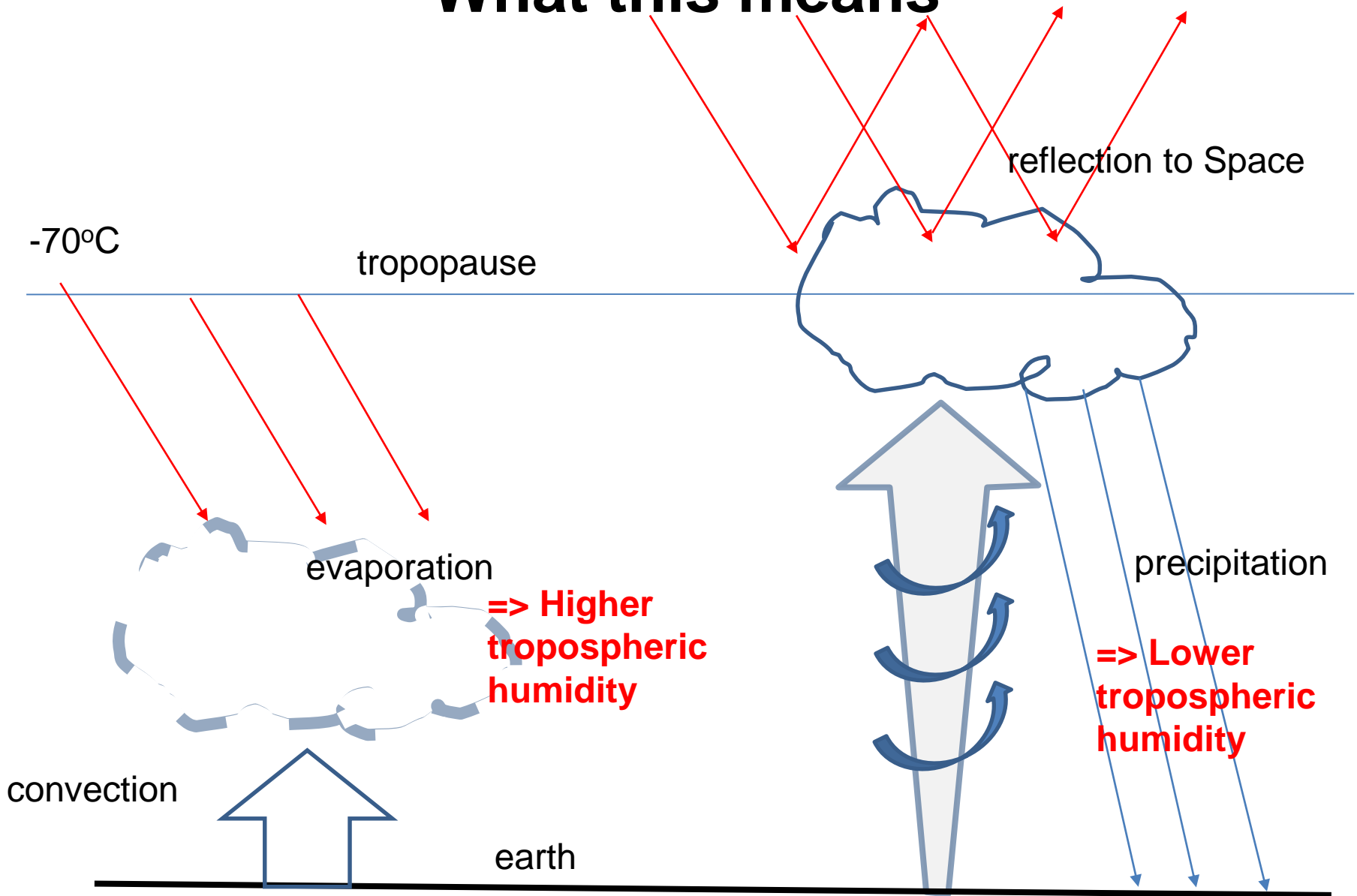

Non-rotating updrafts lead to global warming. Rotating updrafts reduce global warming.

Ramifications

With modest convection updraft velocities, temperature loss from the updraft plume via radiation and mixing may be excessive, leading to:

- a. Ineffective or incomplete convective heat transfer through the troposphere.**
- b. Mid-level clouds. The subsequent evaporation of the clouds boosts the build-up of atmospheric water vapour.**

The high updraft efficiency typical of vortex flow leads to:

- a. High level reflective clouds**
- b. High precipitation efficiency, hence removal of water vapour from the atmosphere**

Tropical Water Vapor Content

- Water vapor content has been increasing (tropics only shown here)

- Big peaks are El Nino events

- Climate models can simulate water vapor content well given sea surface temperatures

Sea temperatures are rising

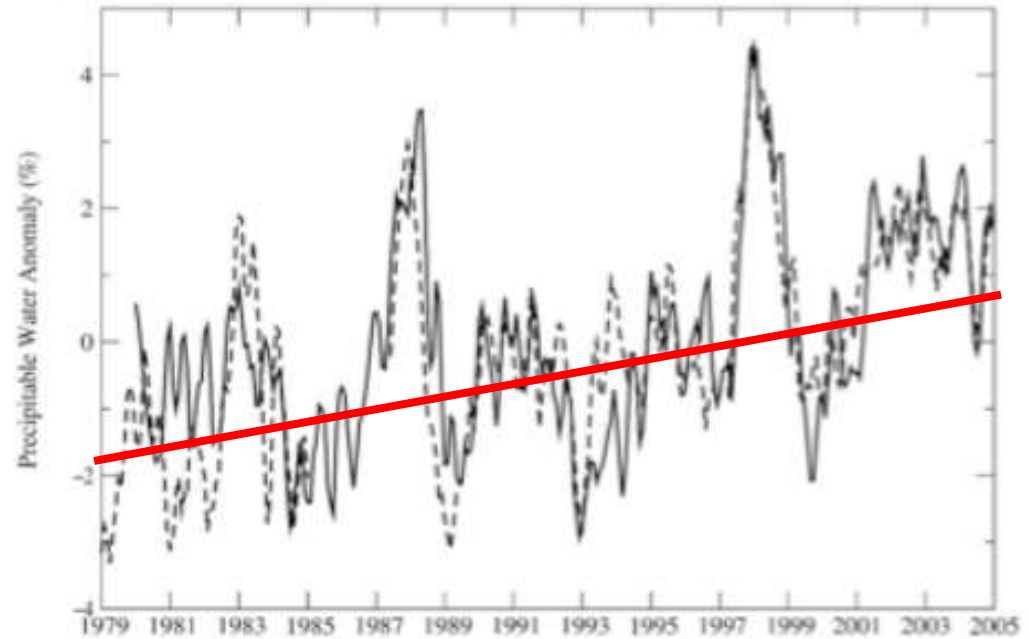

FIG. 1. A time series of the tropical-mean (30°N – 30°S), ocean-only column-integrated water vapor from satellite observations (dashed) and GFDL GCM simulations with prescribed SST (solid). The satellite observations for 1979–84 are from the SMMR (Wentz and Francis 1992) and for 1987–2004 are from the SMM/I (Wentz 1997). The mean seasonal cycle is removed from both the observations and model simulations, and the SMMR anomalies are adjusted such that their mean equals that of the model for their overlapping time period (1980–84). All time series are smoothed using a 3-month running mean.

Water vapour sequestration and storage

One proposal for reducing the greenhouse effect is to sequester and store CO₂.

That is an extremely difficult and costly process.

*There is a cheap and easy alternative:
Remove water vapour on an ongoing basis
and store it below ground and in the
oceans. The vortex engine can do this.*

Earth's Freshwater Resources

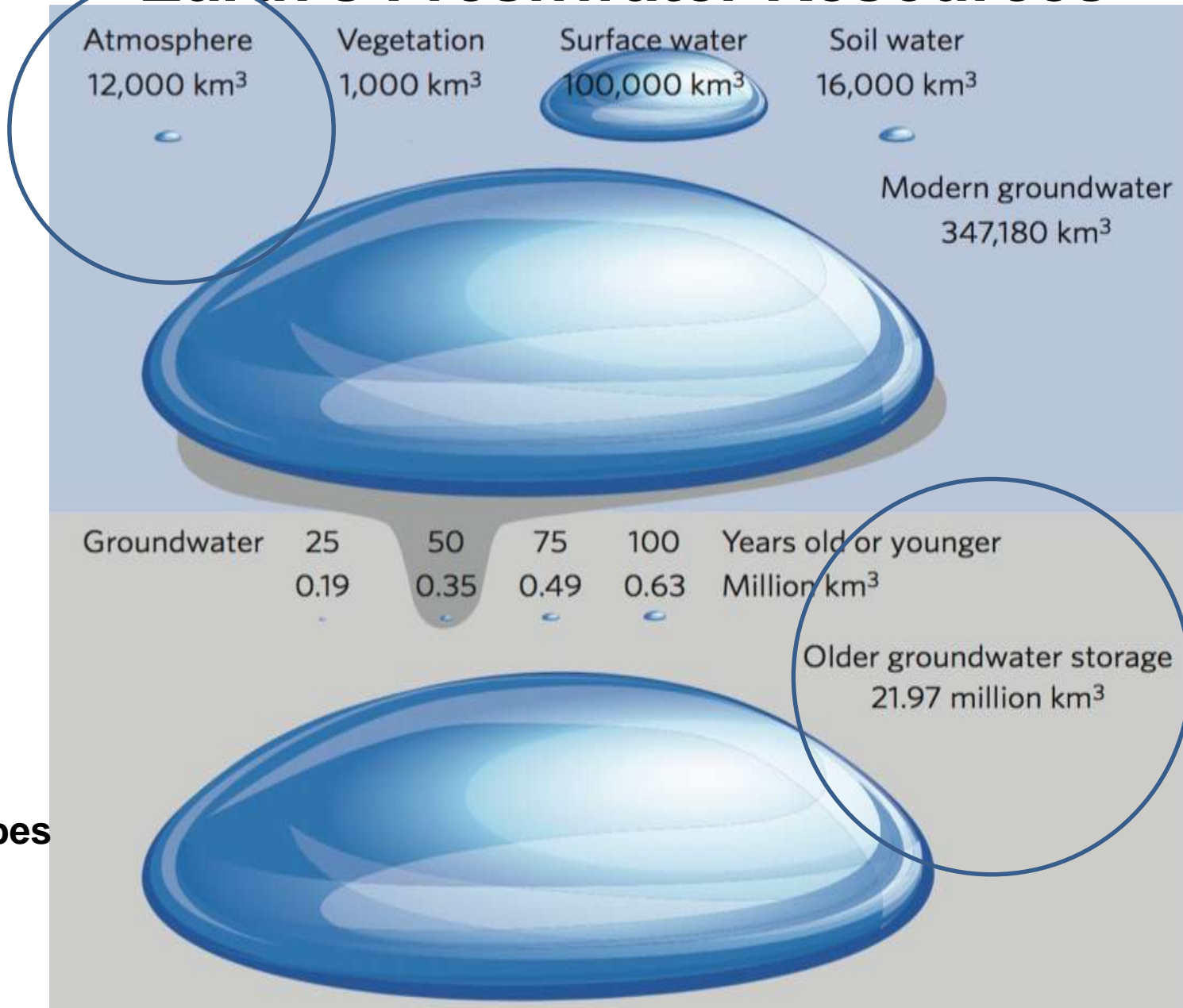

Forbes

The groundwater storage, if laid out over the Earth's land surface of 510 million square kilometres, would have a notional reservoir mean depth of 43 m:

$$\begin{aligned}\text{Depth} &= 22 \times 10^6 / 510 \times 10^8 \text{ km} \\ &= 43 \text{ metres}\end{aligned}$$

Hence the groundwater reservoir capacity is many orders of magnitude greater than that required for control of the atmosphere's water vapour content.

The ramifications of H₂O and CO₂ build-up

There will be climate warming unless there is some sort of negative feedback:

*“...My opinion is that the cloud feedback is the only place where... a large negative feedback [to mitigate global warming] can lurk. **If it is not there, and the planet does not reduce emissions, then get ready for a much warmer climate...**”*

6/01/2010

(Emphasis added)

Professor Andrew Dressler - Department of Atmospheric Sciences of Texas A&M University
<http://pielkeclimatesci.wordpress.com/2010/01/06/guest-post-by-andrew-dessler-on-the-water-vapor-feedback/>

The Heat Pipe

From Computer Desktop Encyclopedia
© 2004 The Computer Language Co. Inc.

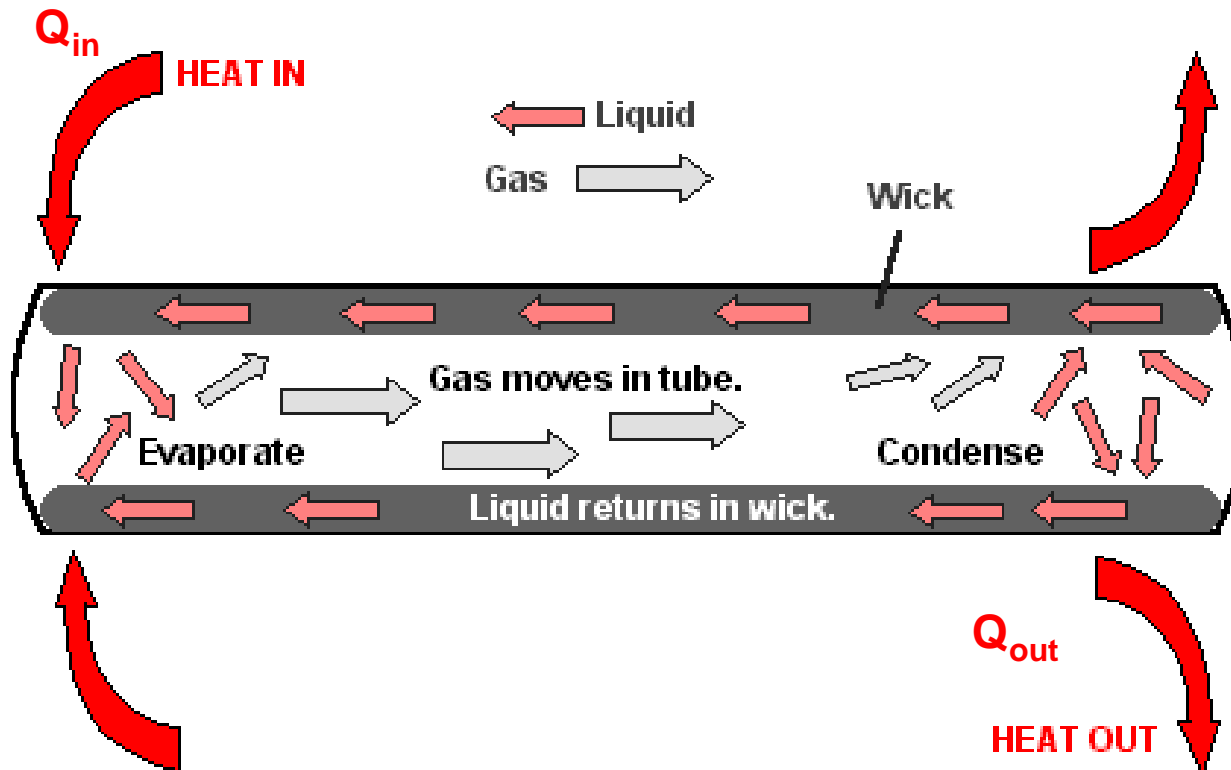

The heat pipe is an extremely effective device for transmitting heat. For equilibrium, the heat input Q_{in} must equal the heat output Q_{out} .

The Troposphere: Nature's "Heat Pipe"

Convection processes such as storms, cyclones and tornados are the primary means of effectively pumping heat out of the ocean, into the atmosphere, and lifting it to where it can be re-radiated into space, thereby mitigating the heat build-up that would otherwise occur.

Cyclones should be regarded as "safety valves" of the atmosphere.

But cyclones are reportedly reducing in frequency:

“There are a number of modelling studies that suggest the frequency or total number of cyclones in some ocean basins, including the South Indian and South Pacific, will decrease as a function of global warming.”

“One recent study examining the frequency of tropical cyclone activity in the Australian region showed that total seasonal cyclone activity was at its lowest level in 1500 years in Western Australia and in 500 years in north Queensland...”

<http://theconversation.com/factcheck-is-global-warming-intensifying-cyclones-in-the-pacific-38984>

And the strongest cyclones are getting stronger:

*“We should not be worried about the frequency of hurricanes; we should be worried about the frequency of intense hurricanes,” said Kerry Emanuel, professor of atmospheric science at the Massachusetts Institute of Technology. **“Climate change is causing a greater number of intense storms...”***

<http://www.livescience.com/28489-sandy-after-six-months.html>

(Emphasis added)

Why are the strongest becoming more frequent?

Cyclone formation is being inhibited by strengthened jet streams in the northern and southern hemispheres:

“...When upper-level winds are present during the hurricane season, the gusts can create wind shear, which greatly inhibits storm formation.

That's because winds blow across the top of the hurricane, preventing the storm's circulation from gaining the momentum it needs to develop more power...”

<http://news.nationalgeographic.com/news/2008/04/080424-winds-warming.html>

“...Records of hurricane activity worldwide show an upswing of both the maximum wind speed in and the duration of hurricanes. The energy released by the average hurricane (again considering all hurricanes worldwide) seems to have increased by around 70% in the past 30 years or so, corresponding to about a 15% increase in the maximum wind speed and a 60% increase in storm lifetime...”

“...the amount of damage increases roughly as the cube of the maximum wind speed in storms, so in practice we are concerned more with intense storms...”

http://eaps4.mit.edu/faculty/Emanuel/publications/position_paper



(NASA)

In new record, three Category 4 hurricanes spin simultaneously in northeast Pacific

By Angela Fritz

August 31, 2015



Fueled by the very warm waters of an ever-strengthening El Niño, the 2015 Pacific hurricane season reached new heights over the weekend thanks to hurricanes Kilo, Ignacio and Jimena, whirling elegantly across



Temperature profiles of updraft vortices within the troposphere

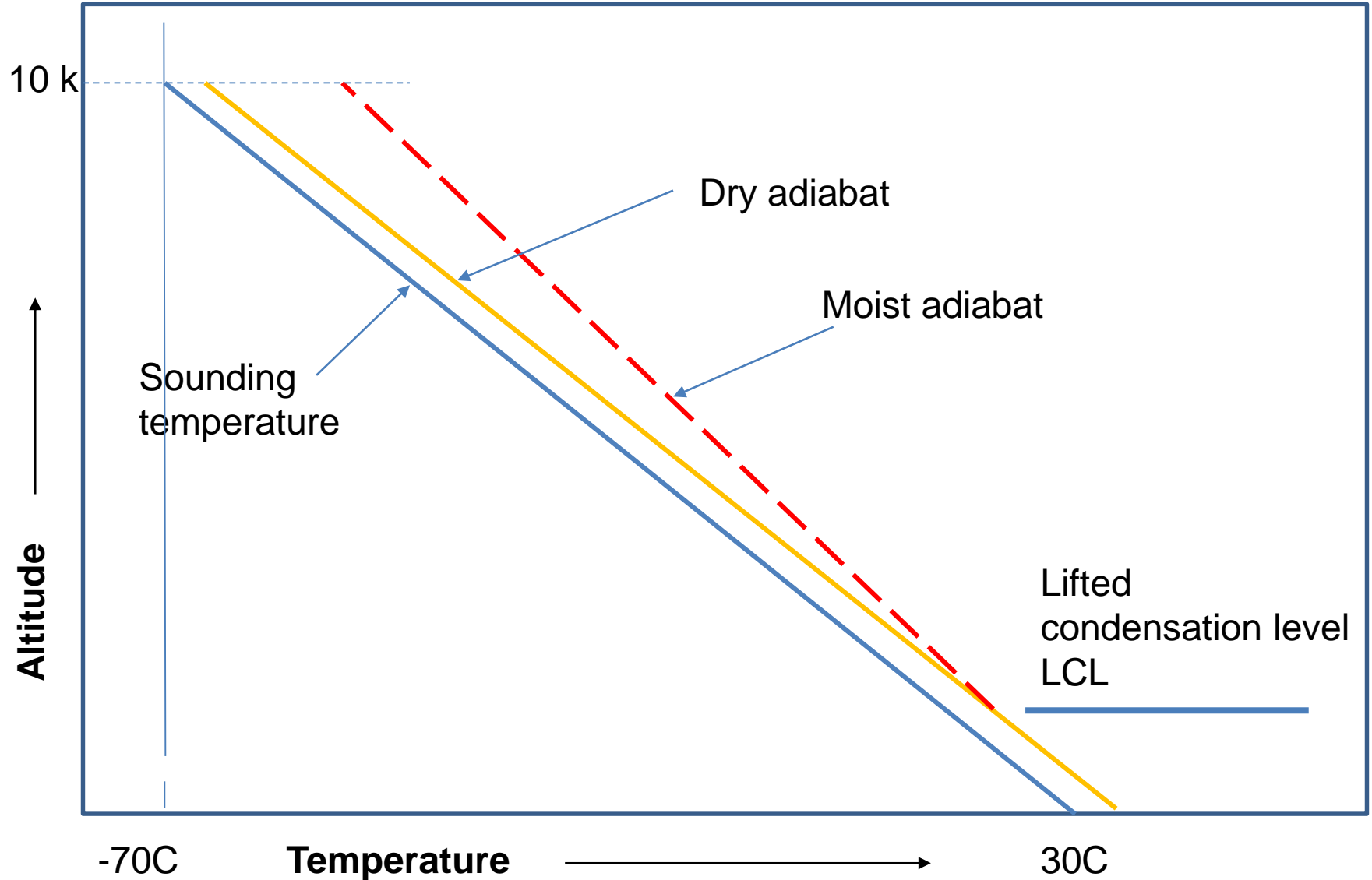

Ideal temperature profile graph for updraft vortices within the troposphere

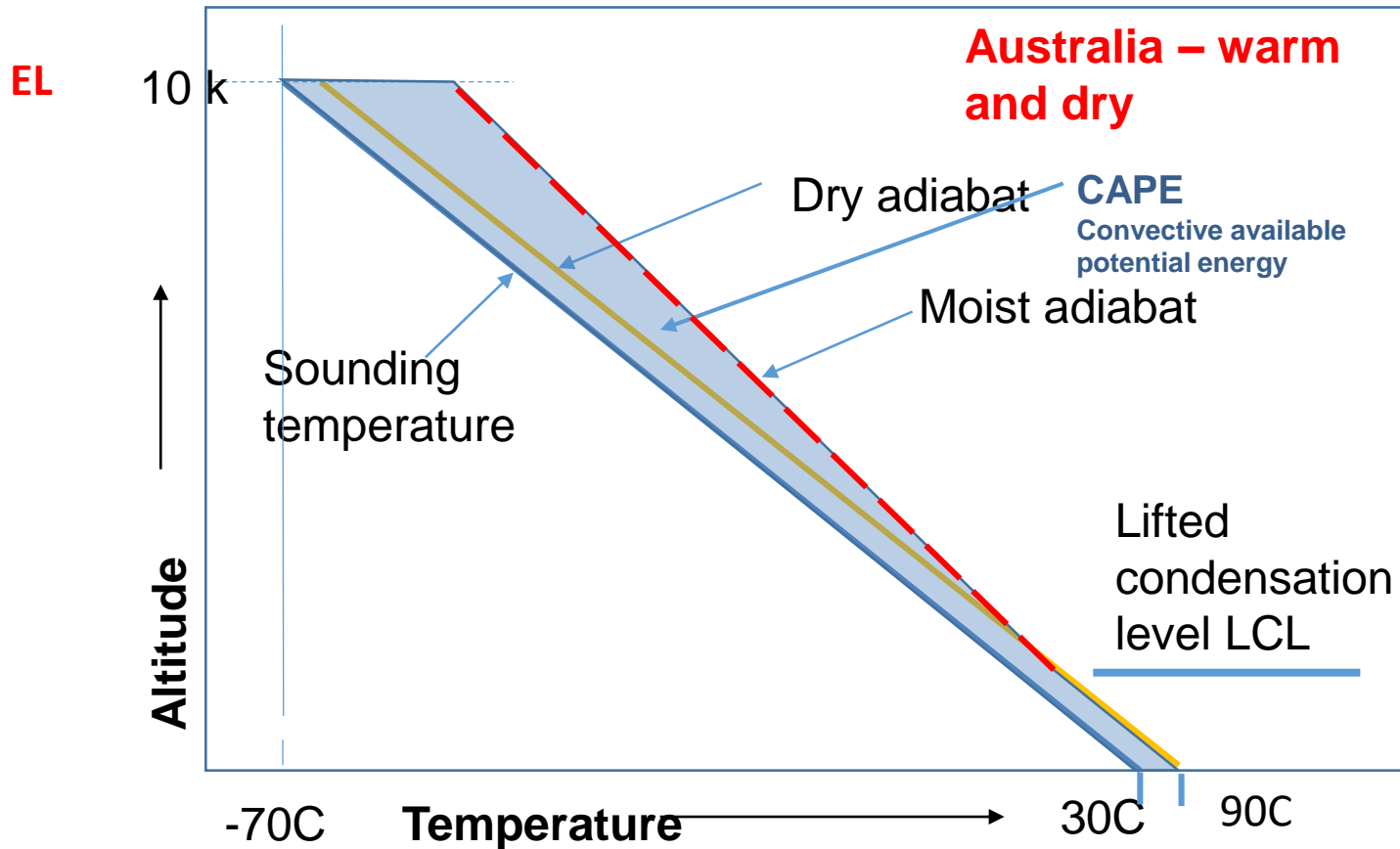

Ideal temperature profile graph for updraft vortices within the troposphere

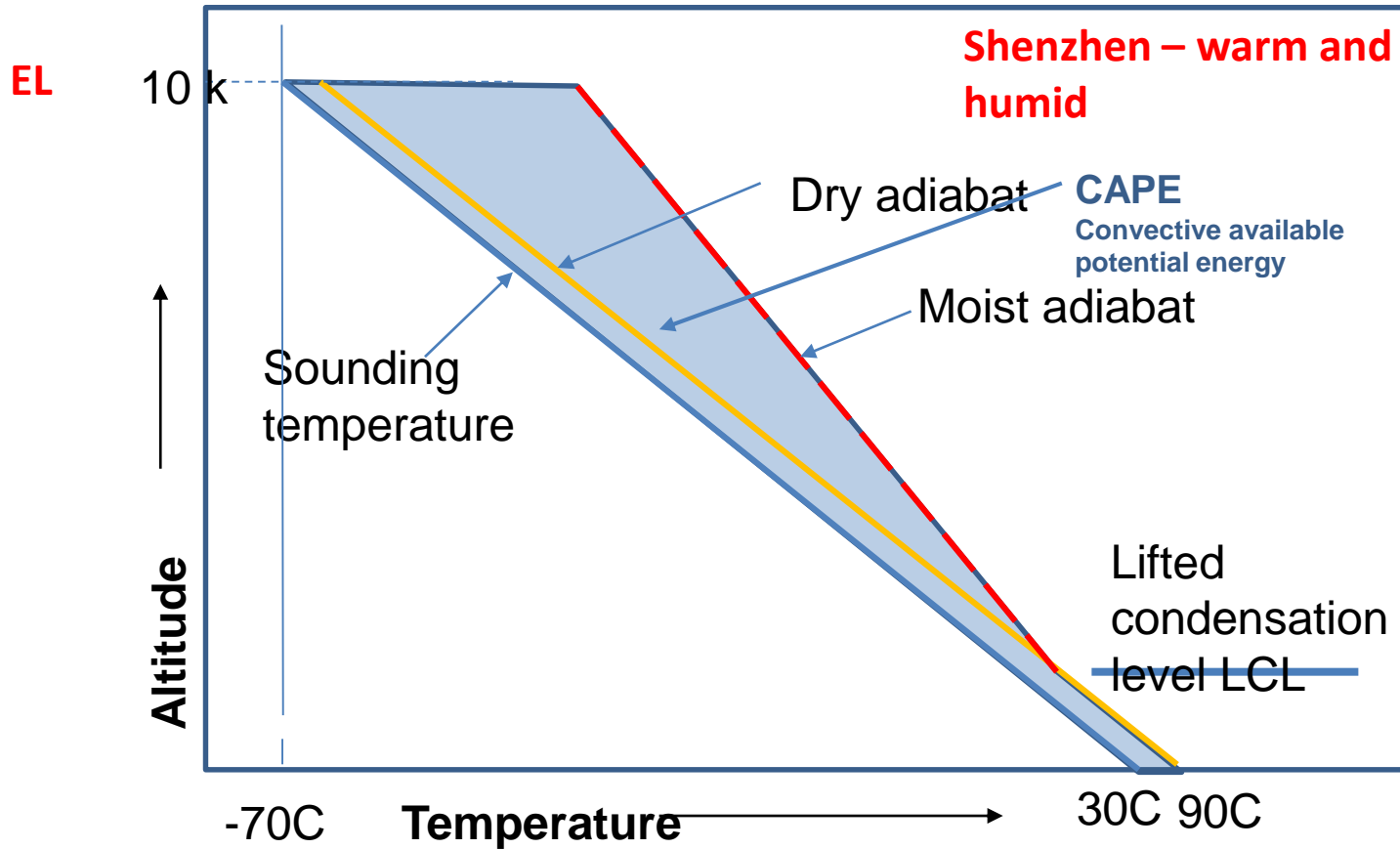

Assuming 2% water vapour by weight – ideal CAPE is

Ideal temperature profile graph for updraft vortices within the troposphere

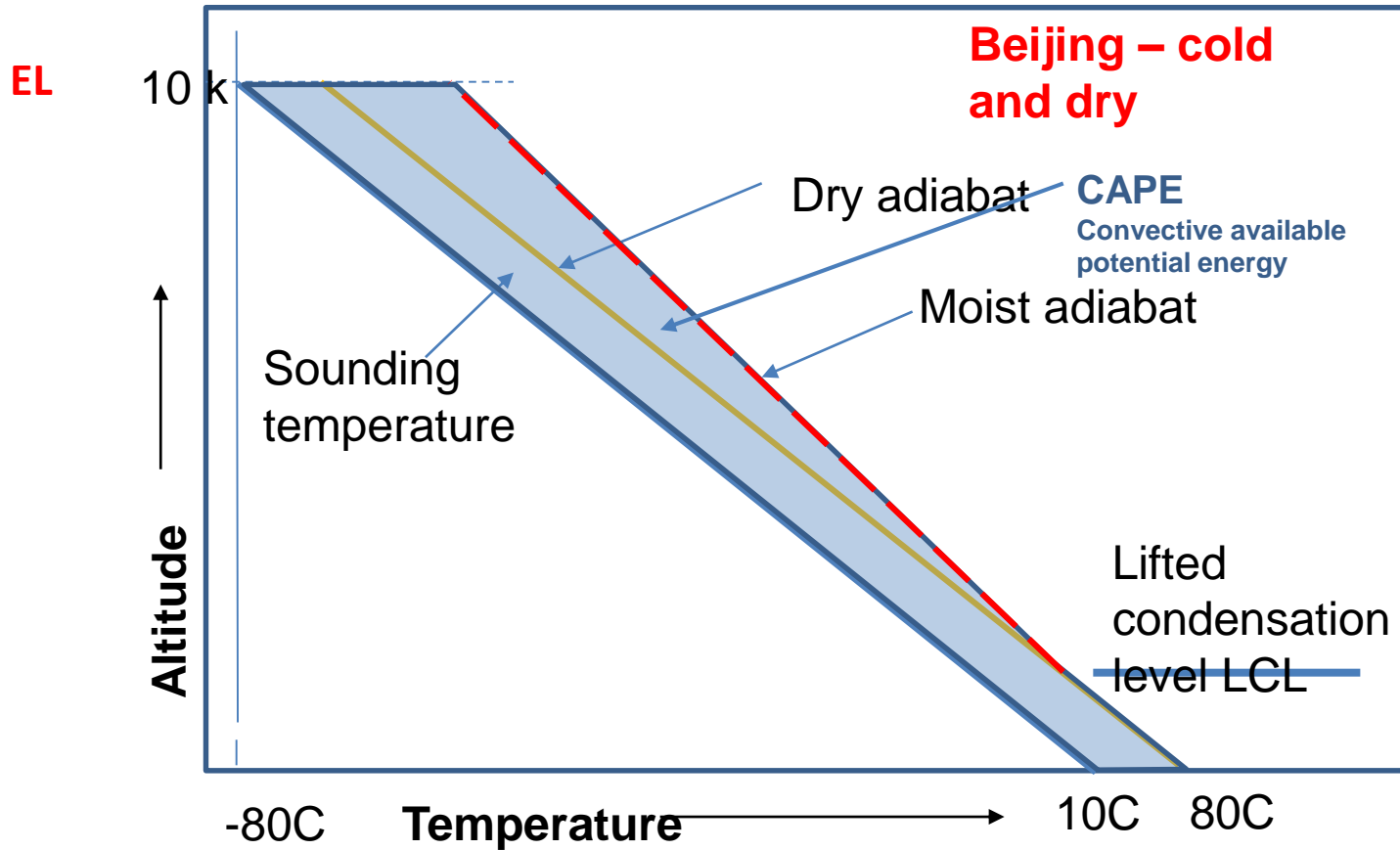

Heat loss from the plume

The ideal temperature profile of the dry and moist adiabats assume that:

- No heat is transferred from the updraft plume by radiation or conduction
- There is no mixing of the plume air with the surrounding atmosphere

This is an approximation of what happens within an updraft vortex.

Oxygen and nitrogen, which together make up 98% of the atmospheric air, have very low emissivities in the frequency band (infra-red) where radiation would otherwise occur.

As discussed, the vortex mechanism acts to sequester the plume from the surrounding atmosphere, thus severely limiting conduction and mixing.

The Vortex Engine can leverage heat transfer by use of the energy of atmospheric water vapour

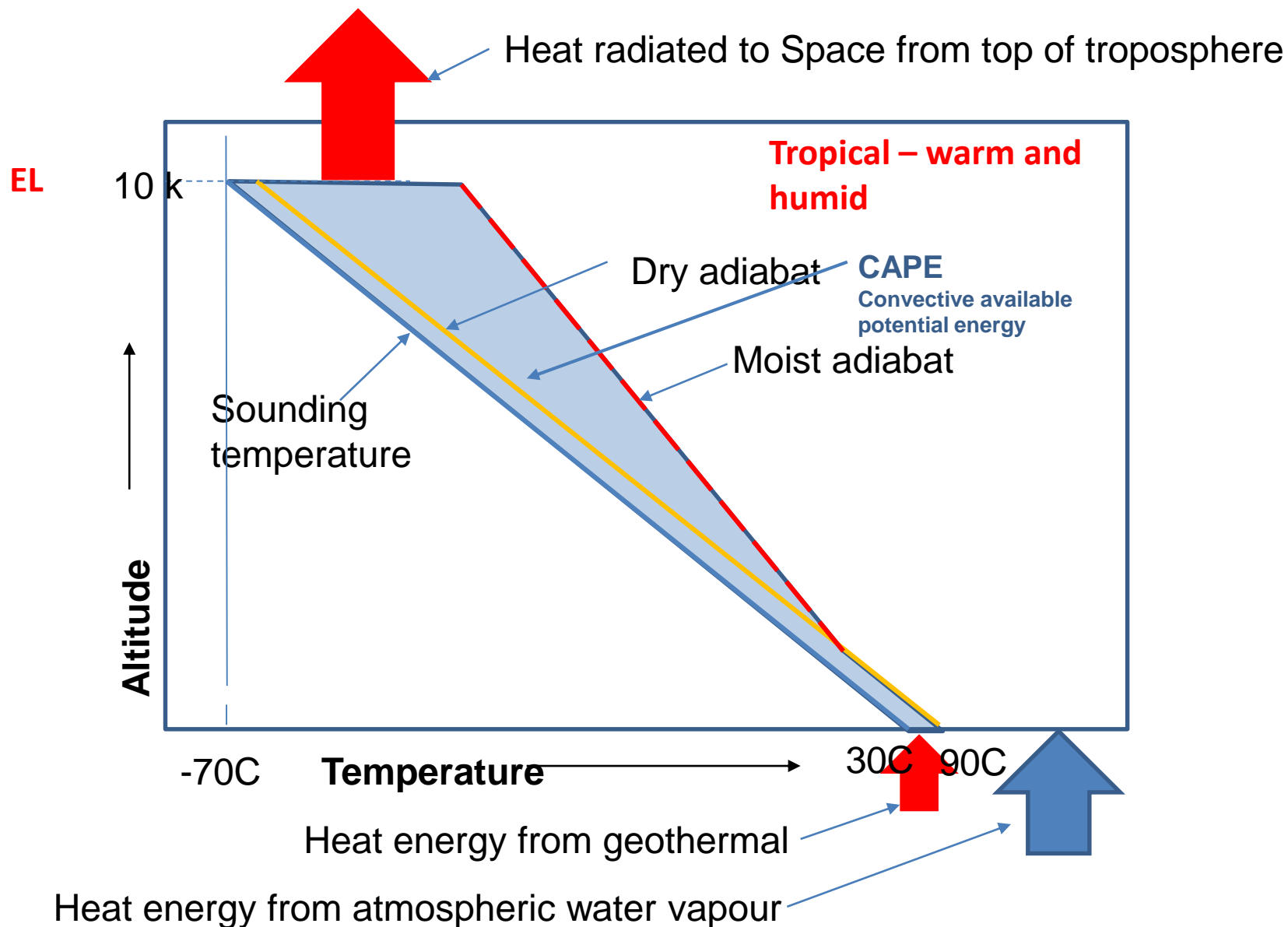

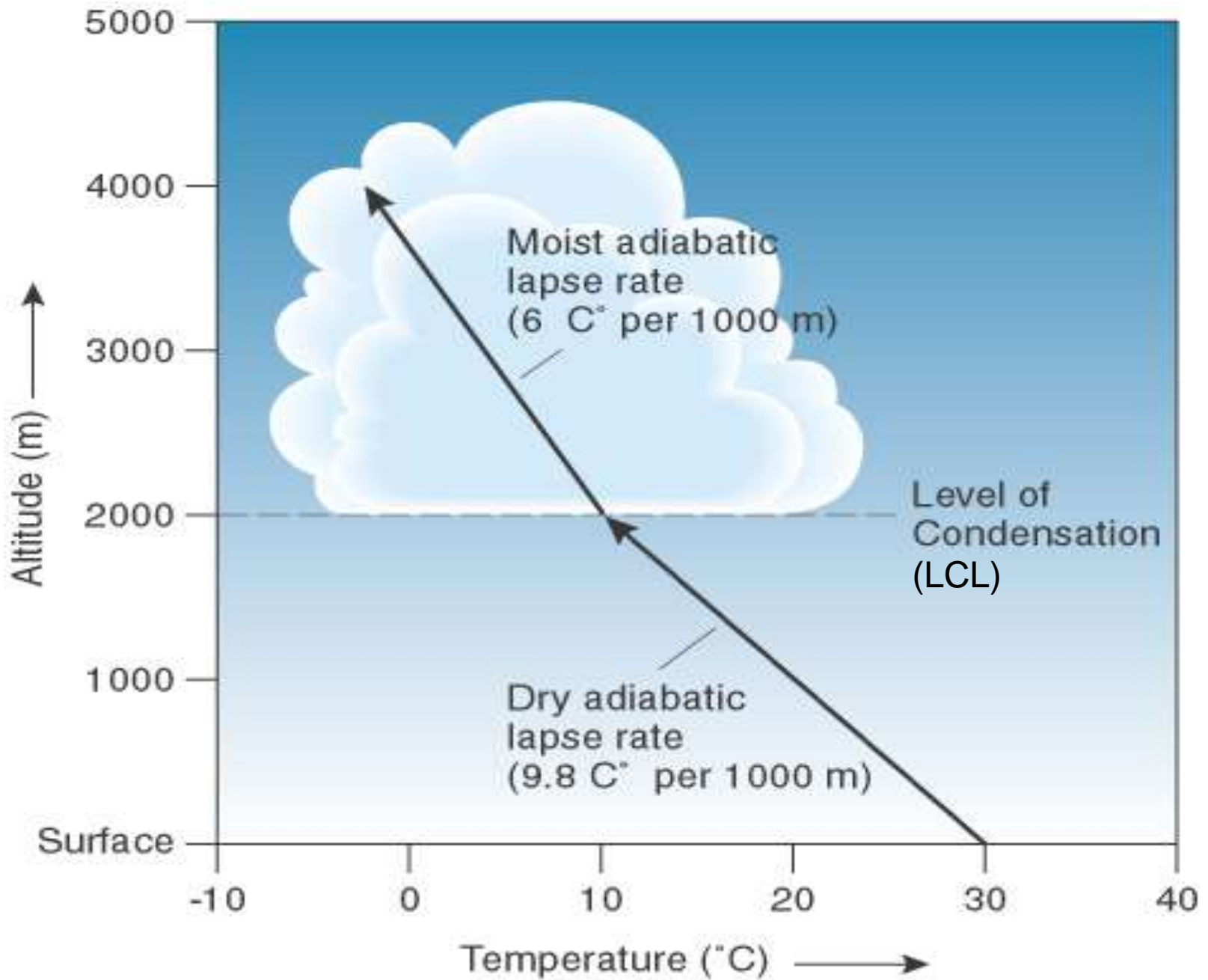

“Speed Bumps” in the temperature profile

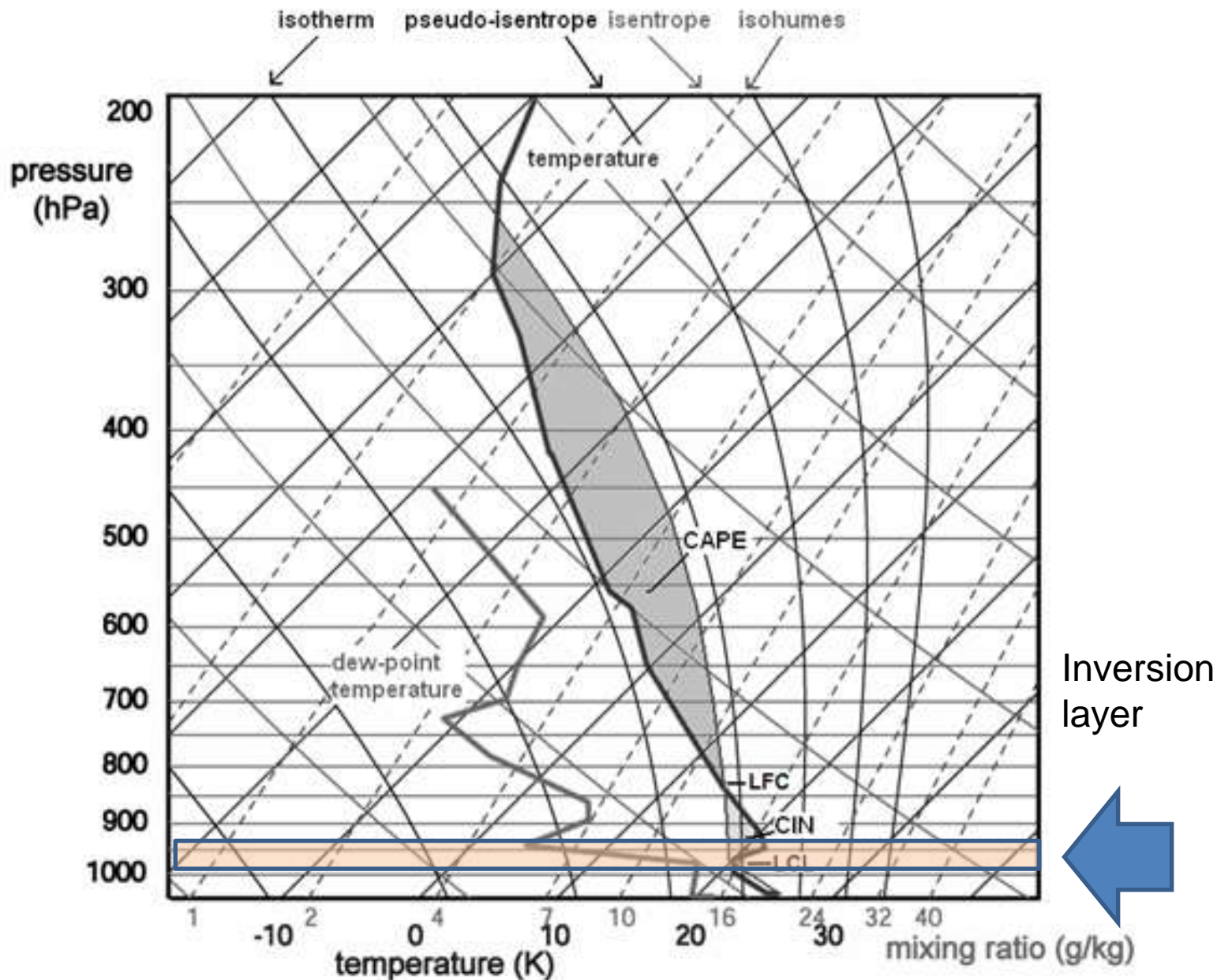

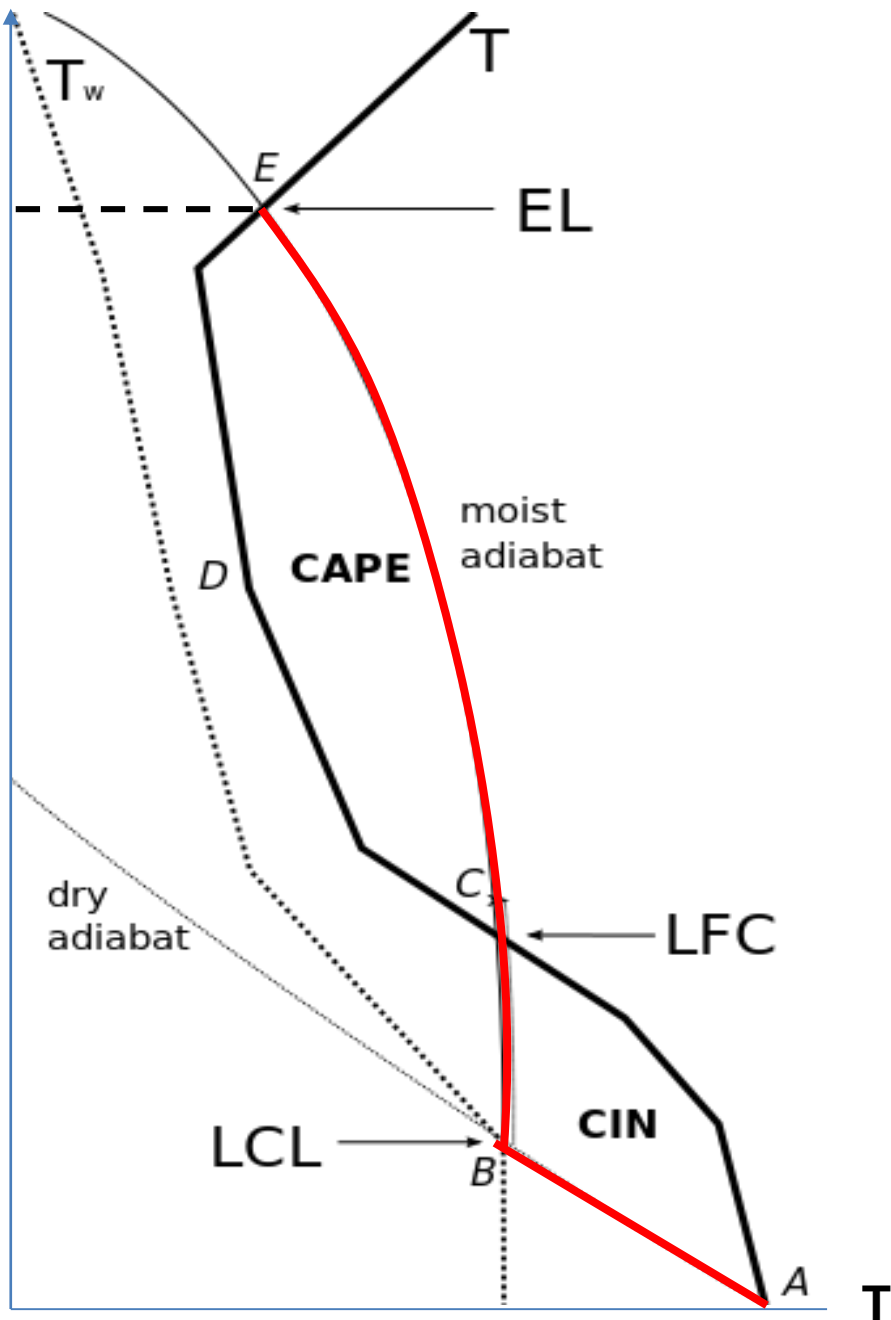

Diagram showing an air parcel path when raised along A-B-C-E compared to the surrounding air mass Temperature (T) and dew point temperature (T_w)

An air parcel heated by the earth follows a dry adiabat up to the LCL

and then a moist adiabat up to the EL (equilibrium level) at the top of the troposphere

The **level of free convection (LFC)** is the altitude in the atmosphere where the temperature of the environment decreases faster than the moist adiabatic lapse rate of a saturated air parcel at the same level.

CAPE = convective available potential energy

CIN = Convective inhibition

Inversion layers interfere with the convection process

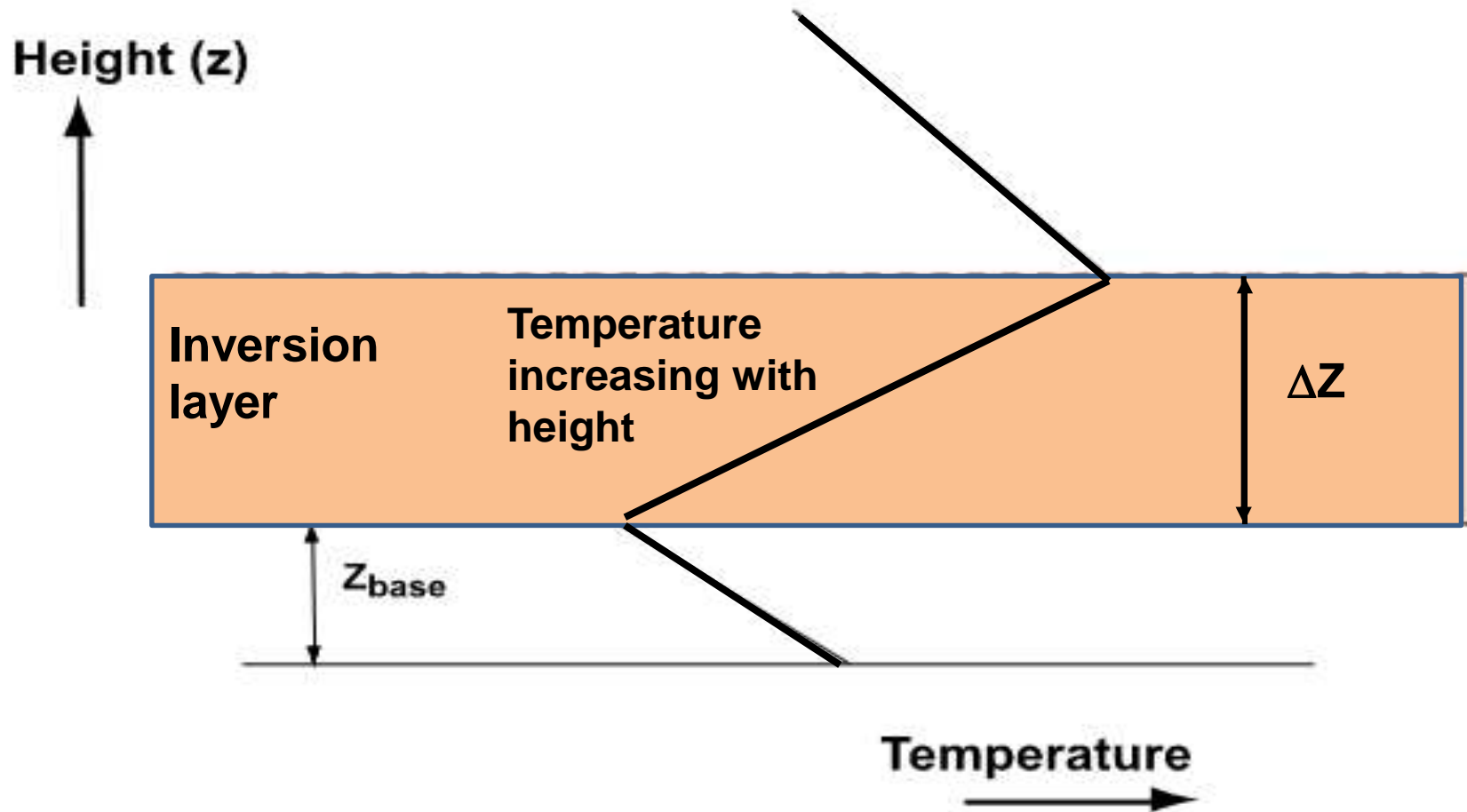

Inversion layers tend to inhibit convection because the updraft has to be able to overcome the negative buoyancy while going through the inversion. The vortex engine will enable the plume to break through to the free convection zone

Inversion layer formation

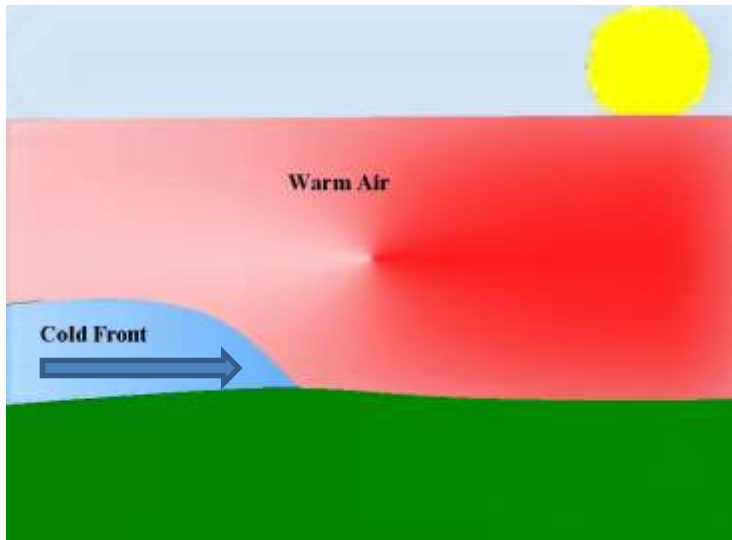

Cold front inversion

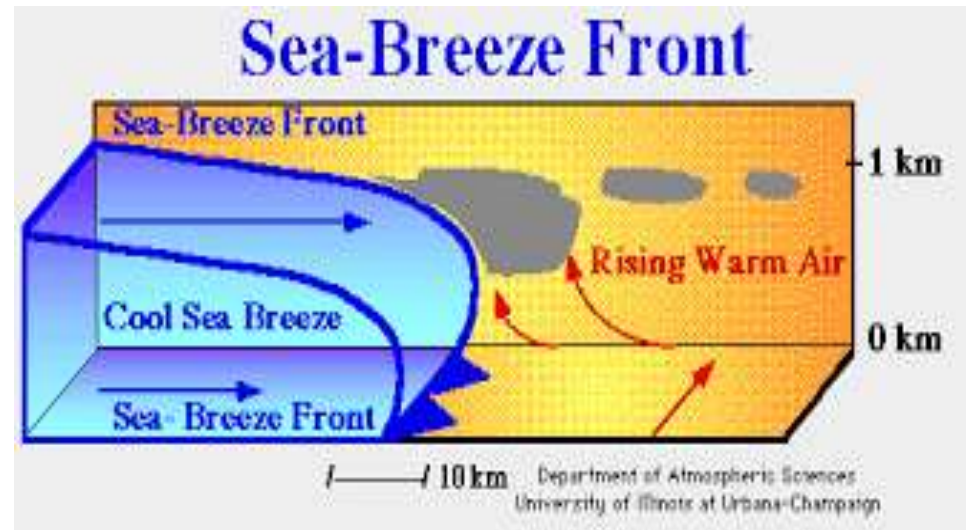

Marine inversion

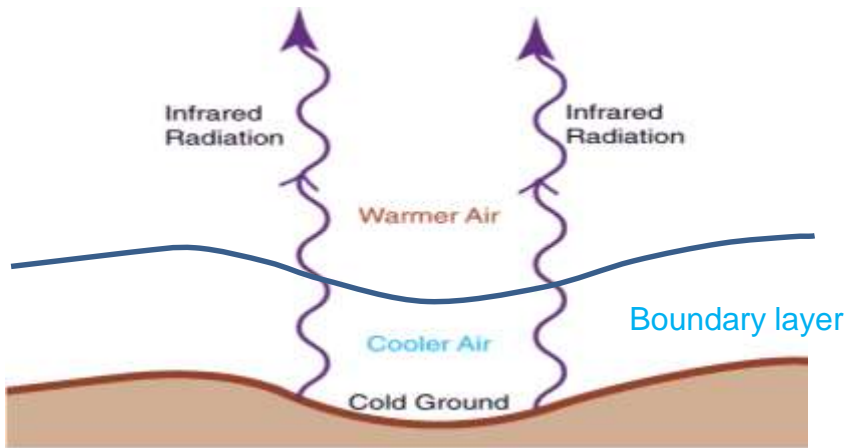

Radiation inversion

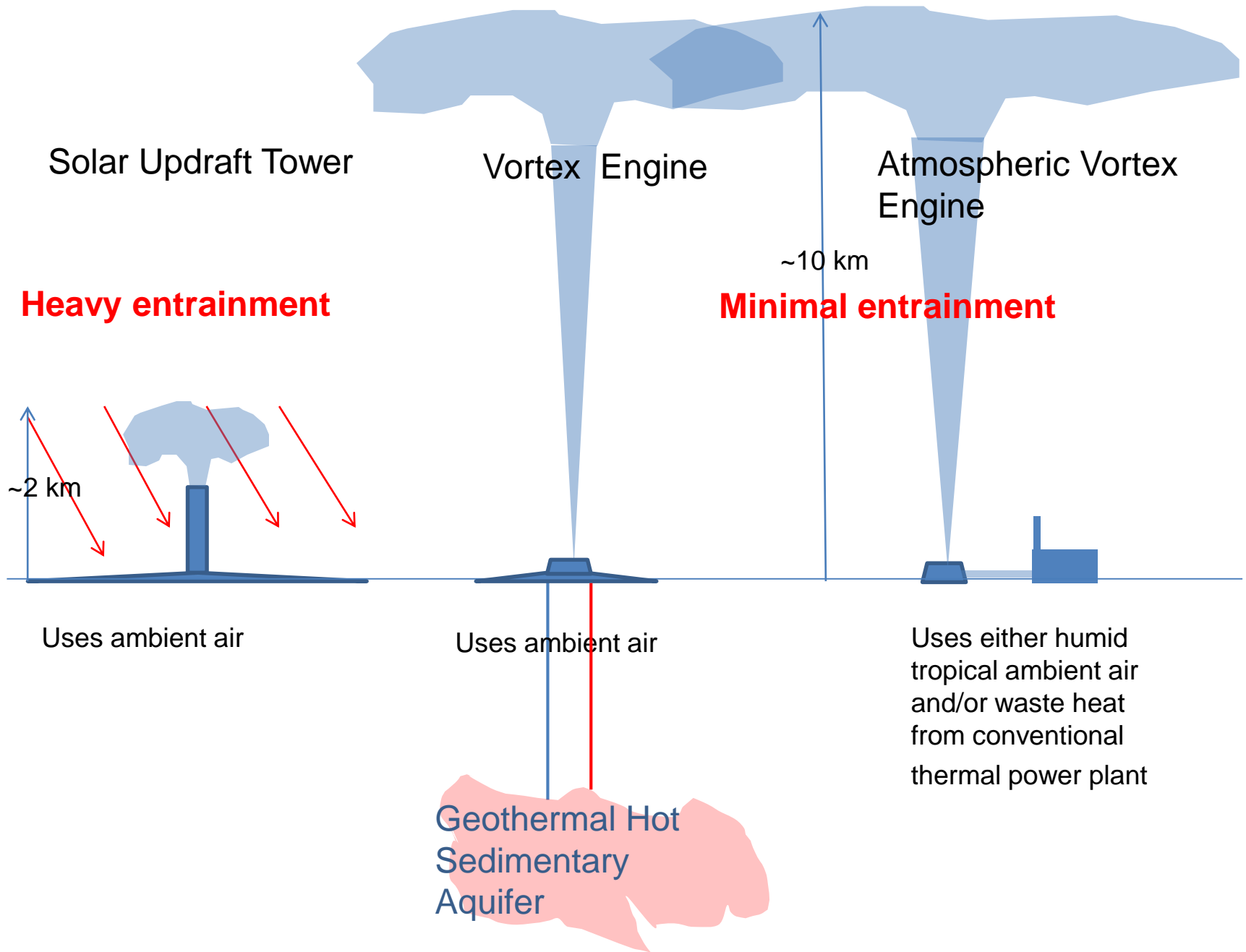

Natural convective vortices



*Image Credit: ©Troy
Bourne / Perth Weather
Live*

A large dust devil near Port Hedland. The stack on the left is 116m high!

<https://pwlinfo.wordpress.com/2013/11/20/willy-willy-dust-devil-or-cockeyed-bob/>

Progress in funding for Vortex Engines

- PayPal co-founder and Facebook investor, Peter Thiel, funded construction of a Canadian prototype to US\$300,000 in 2012. This system is intended to ultimately utilise waste heat from power station cooling towers
- The US Department of Energy through the Advanced Research Projects Agency-Energy (ARPA-E) has funded a group led by Georgia Institute of Technology (GATECH) for US\$3.7 million in 2014. This system is intended to utilise solar energy within arid regions.

- The Canadian concept is for a stand-alone power plant with a capacity of about 200 MWe
- The GATECH concept is based (at least initially) on using a large array of relatively small vortex engines each of around 50 kWe, with a combined output of around 16 MWe/km².

“Reap the whirlwind for cheap renewable power”

New Scientist

11 March 2013 by Hal Hodson

<http://www.newscientist.com/article/mg21729075.400-reap-the-whirlwind-for-cheap-renewable-power.html#.VaHVMfmqqkp>

Article on the Gatech research project:

“...Simpson has tested a small, 1-metre version of the vortex that drives a turbine to create a few watts of power using nothing more than a hot, sun-baked metal sheet. However, the power output scales up rapidly as you increase the turbine's diameter.

Simpson calculates that a 10-metre turbine will produce 50 kilowatts of power using the same method. The team says that an array of these vortex turbines could produce 16 megawatts for every square kilometre they cover. This is not bad considering conventional wind turbines yield just 3 and 6 megawatts per square kilometre.

In fact, the team estimates that the electricity produced by a Solar Vortex will be 20 per cent cheaper than energy from wind turbines and 65 per cent cheaper than solar power.”

“Dust Devils Power Energy Machine”

Discovery Magazine

Feb 28, 2013 by Eric Niiler

<http://news.discovery.com/tech/alternative-power-sources/dust-devils-power-energy-machine-130228.htm>

ARPA-E quote:

“It’s part of our mission to look for disruptive energy technologies that are typically earlier stage and higher risk than other agencies or commercial entities would take on,” Willson said. “They also have to be based on sound science.” ’

- The GaTech consortium's proposed array of moderately-sized vortex engines has the advantage of keeping the energy level at each engine relatively low, and hence providing a "stepping stone" to a full scale system.

The disadvantages of a 10 m dia. system would be:

- The power of the updraft plume is insufficient to penetrate inversion layers and other conditions of convective inhibition.
- With a plume height of approximately 1 km, a maximum thermal efficiency in the region of only 3% could be expected, as against around 30% for that for the full tropospheric-scale (10 km) concept.

Will vortices work?

*‘...**Nilton Renno**, a professor at the department of atmospheric, ocean and space sciences at the University of Michigan, has spent his career studying tornadoes and water spouts. He says there is no reason why [the] vortex engine wouldn’t work.’*

Still, Renno isn't without reservations. He's particularly concerned about the ability to control such a powerful monster.

"The amount of energy involved is huge. Once it gets going, it may be too hard to stop," he says.

The Toronto Star, July 21 2007

“...‘The science is solid,’... ‘Once you induce circulation nearby, the vortex can be self-sustaining.’”

Discovery, Feb 28 2013

*“...What’s necessary at this point is to do proofs of concept,” says professor **Kerry Emanuel**, the hurricane expert at MIT. “[The] idea is pretty simple and elegant. My own feeling is that we ought to be pouring money into all kinds of alternative energy research. There’s almost nothing to lose in trying this...”*

ODE Magazine, March 2008

Conclusions

- **Convection within the troposphere is critical in order to prevent global warming**
- **Convection is currently significantly inhibited by several atmospheric mechanisms including**
 - **Inversion layers**
 - **Atmospheric brown clouds**
- **The atmospheric vortex engine can arguably help to overcome these inhibitory factors and in doing so yield significant energy, additional precipitation and a cooler atmosphere**

**NATURÆ ENIM NON IMPERATUR,
NISI PARENDO**

**WE CANNOT COMMAND NATURE
EXCEPT BY OBEYING HER**

Francis Bacon

Quick Links:

The AVETec Website:

<http://vortexengine.ca>

The Sky's the Limit (ASME Mechanical Engineering Journal)

http://memagazine.asme.org/Articles/2011/April/Skys_Limit.cfm

Buoyancy-Induced Columnar Vortices for Power Generation

- <http://www.fmrl.gatech.edu/drupal/projects/solarvortex>
- <http://arpa-e.energy.gov/?q=slick-sheet-project/power-generation-using-solar-heated-ground-air>
- <http://news.discovery.com/tech/alternative-power-sources/dust-devils-power-energy-machine-130228.htm>
- <http://www.newscientist.com/article/mg21729075.400-reap-the-whirlwind-for-cheap-renewable-power.html#.VaHVMfmqqkp>

Gravity Towers

<http://www.ecochunk.com/5962/2013/02/04/downdraft-tower-uses-solar-energy-to-produce-wind-for-low-cost-wind-power/>

Amazon Rainforest

<http://www.i-sis.org.uk/importanceOfTheAmazonRainForest.php>

Contact:

vortexengineer@gmail.com

Scientific American

August 2015

Energy, Water and Food Problems Must Be Solved Together

Our future rides on our ability to integrate how we use these three commodities

By Michael E. Webber

“In July 2012 three of India's regional electric grids failed, triggering the largest blackout on earth. More than 620 million people - 9 percent of the world's population—were left powerless.”

“The cause: the strain of food production from a lack of water. Because of major drought, farmers plugged in more and more electric pumps to draw water from deeper and deeper below ground for irrigation. Those pumps, working furiously under the hot sun, increased the demand on power plants. At the same time, low water levels meant hydroelectric dams were generating less electricity than normal...”

BACKGROUND MATERIAL

Water harvesting

Professor Kerry Emanuel MIT

"...they have created what they call a dynamic chimney where they create a giant greenhouse over the desert floor and in the middle of the glass you have a chimney... The sun makes it very hot in there and the air goes rushing up the chimney, and you apply a swirl to that, which is essentially a tornado. The beauty of it is that once it leaves the chimney it keeps going and that is important because the thermodynamic efficiency of the engine is basically proportional to the temperature difference between the bottom and the top, and 100 feet is tall enough for that temperature difference to be appreciable, but if the column of rotating air goes a kilometre into the sky, you now have a change in temperature of about 10 degrees, and they use that to generate electricity."

"If salt water is used instead of just the desert surface, you have a much higher albedo [reflectivity] so you get more efficient generation. You get moist air going up, which means it can go higher into the atmosphere, and then the rain that comes down can be harvested into fresh water!..."

Worldchanging Interview: Kerry Emanuel, Climate Scientist

David Zaks, 27 Feb 07

Hybrid Power and Water Production

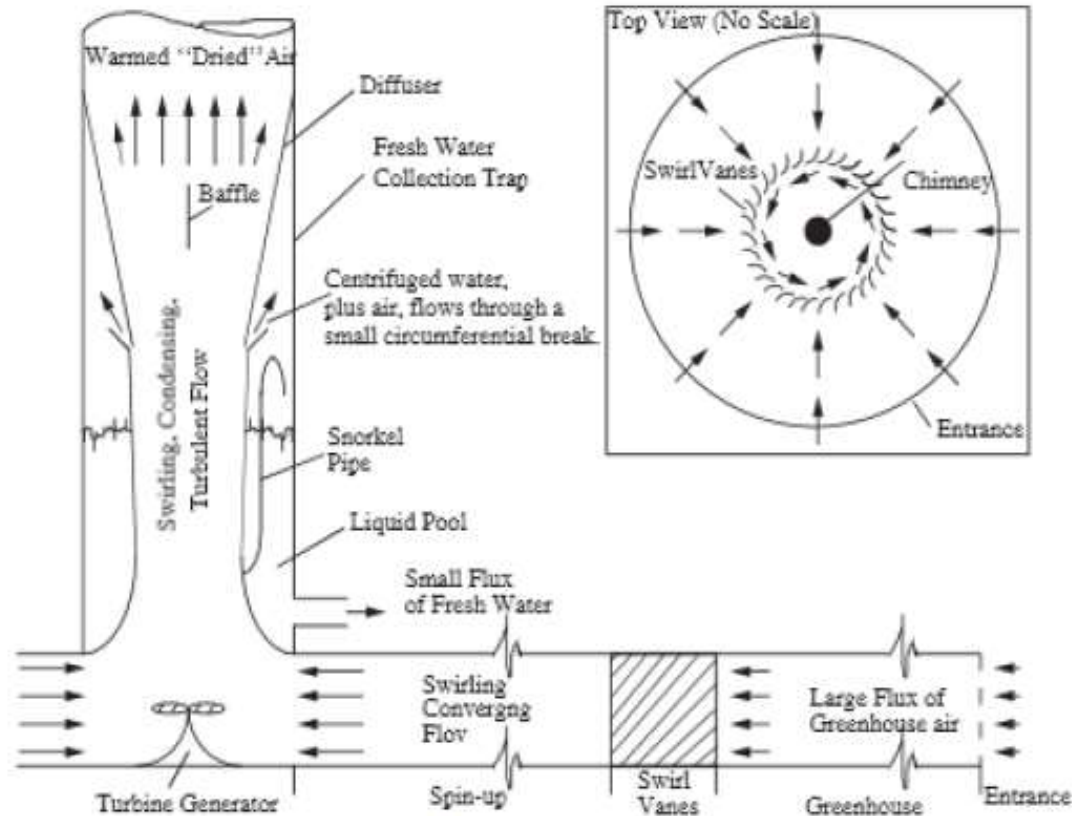

Fig. 4: Schematic of the expansion cyclone separator [15]

Another method of getting water

Kashiwa BA; Kashiwa, CB (2008). "The solar cyclone: A solar chimney for harvesting atmospheric water". *Energy* 33 (2): 331–339.

Zhou, X.; Xiao, B.; Liu, W.; Guo, X. et al. (2010). "Comparison of classical solar chimney power system and combined solar chimney system for power generation and seawater desalination"

Impediments to natural convection within the troposphere

Marine Inversion

2.41 Distance inland

AUSTRALIA

In the 1950s it was discovered that the **sea breeze** could be detected at what seemed to be vast distances inland. Measurements of 'inland surges connected with the **sea breeze**' were made at several points along the south coast. Starting from Esperance in Western Australia, using a line of stations measuring pressure, temperature and humidity, **sea-breeze** surges were traced as far as **Kalgoorlie**, 290 km from the coast (Clarke, 1955). Further east, in Victoria and New South Wales, similar inland penetration was found.

The Effect of Inversions

NORMAL SITUATION

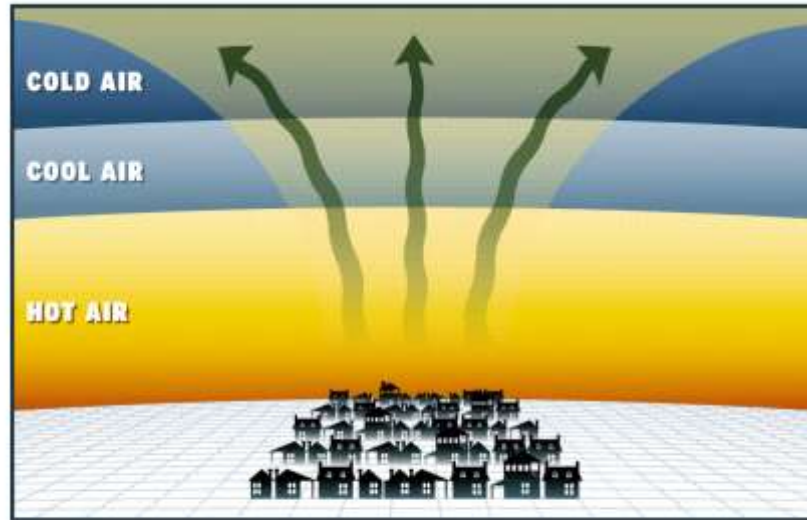

TEMPERATURE INVERSION

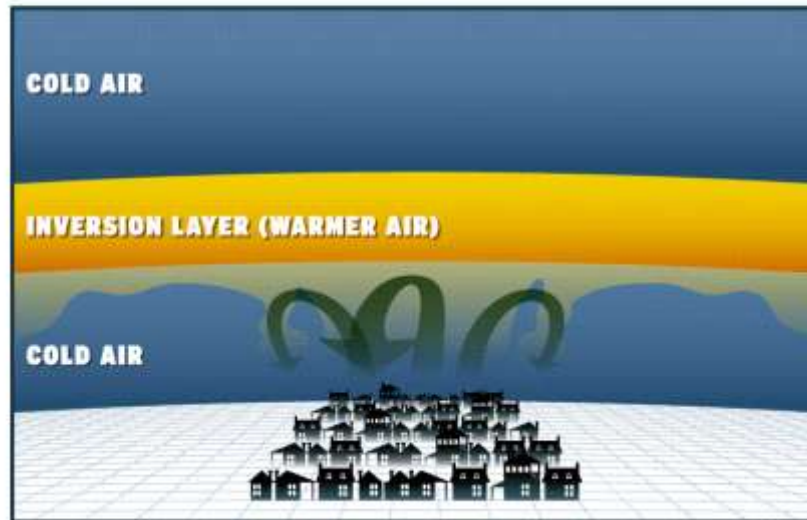

At any given time, a significant percentage of the Australian continent could be expected to be “blanketed” by temperature inversions of some type, thus inhibiting convection. Even without an inversion, an inhibited convective layer often occurs in the first approx. 2 km.

The vortex engine of the right scale would enhance convection in the troposphere. This would arguably cool the local environment and create a positive feedback loop to reverse desertification in the interior of the continent.

There is evidence that gradual convection is relatively inefficient in reducing the greenhouse effect. With higher atmospheric temperatures, low to medium level clouds which form have a correspondingly increased evaporation rate and hence dissipate more quickly:

Steven Sherwood, a climate scientist at Australia's Centre of Excellence for Climate System Science and lead author of the report, says the prediction of a 4° Celsius warming is based on the role of water vapour in cloud formation.

“What we see in the observations is that when air picks up water vapour from the ocean surface and rises up, it often only rises a few kilometres before it begins its descent back to the surface,” Sherwood said. “Otherwise it might go up 10 or 15 kilometres. And those shorter trajectories turn out to be crucial to giving us a higher climate sensitivity because of what they do to pull water vapour away from the surface and cause clouds to dissipate as the climate warms up.”

<http://www.voanews.com/content/study-warmer-world-will-produce-fewer-clouds/1822952.html>

Fast convection producing high level [rain] clouds also has the effect of producing a drier atmosphere, as much of the precipitation enters the ground-water system or is returned to the ocean. As water vapour is the most critical greenhouse gas, this would also reduce the greenhouse effect.

Aerosols in the atmospheric brown cloud have also been shown to reduce the strength of the global monsoon system (see later).

Possible Negative Feedback from Cloud Cover

“...Given the strong water vapor feedback seen in observations ($\sim 2 \text{ W/m}^2/\text{K}$), combined with estimates of the smaller ice-albedo and lapse rate feedbacks, we can estimate warming over the next century will be several degrees Celsius. You do not need a climate model to reach this conclusion — you can do a simple estimate using the observed estimates of the feedbacks along with an expectation that increases in carbon dioxide will result in an increase in radiative forcing of a few watts per square meter.

The only way that a large warming will not occur in the face of these radiative forcing is if [there is] some presently unknown negative feedback that cancels the water vapor feedback. My opinion is that the cloud feedback is the only place where such a large negative feedback can lurk. If it is not there, and the planet does not reduce emissions, then get ready for a much warmer climate...”

Professor Andrew Dressler - Department of Atmospheric Sciences of Texas A&M University

<http://pielkeclimatesci.wordpress.com/2010/01/06/guest-post-by-andrew-dessler-on-the-water-vapor-feedback/>

The Vortex Engine’s high level cloud production in conjunction with reforestation should significantly increase local cloud cover.

The Interrelationship between Insolation and Precipitation

The average annual precipitation of the entire surface of our planet is estimated to be about 1050 millimetres per year. (Source PhysicalGeography.net).

The average global insolation at the surface of the Earth is estimated as 180 W/m^2 (Source PhysicalGeography.net). Over one year, this would be equivalent to the energy required to produce an evaporation rate of about 1600 millimetres, but part of the energy would inevitably go to heating atmospheric air.

Hence around two thirds of the solar energy reaching the Earth's surface goes to the evaporation of water and creation of a "heat pipe" effect, which eventually dumps heat back to Space.

Global Warming predictions

The following text is extracted from MIT Professor Kerry Emanuel's book "**What We Know About Climate Change**," published in 2007. It appears to be apposite to the current situation:

- The global mean temperature is now greater than at any time in at least the past 500 to 1,000 years...
- **Rainfall will continue to become concentrated in increasingly heavy but less frequent events.**
- **The incidence, intensity, and duration of both floods and drought will increase.**
- **The intensity of hurricanes will continue to increase, though their frequency may dwindle.**

Even if we believed that the projected climate changes would be mostly beneficial, we might be inclined to make sacrifices as an insurance policy against potentially harmful surprises.

The Atmospheric Temperature Profile

The Atmospheric Temperature Profile

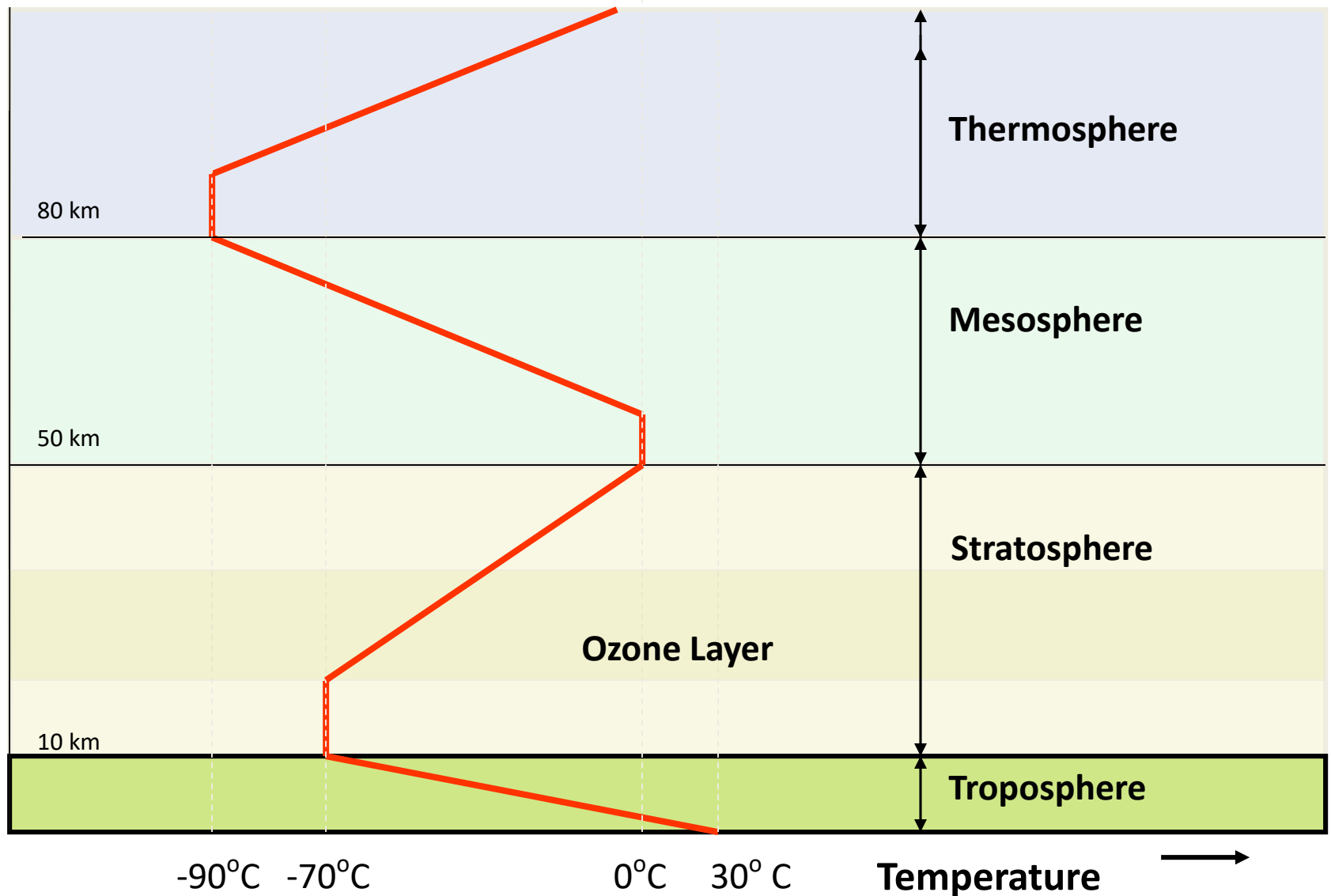

SIMPLIFIED GRAPH OF ATMOSPHERIC TEMPERATURE PROFILE

The Atmospheric Temperature Profile:

With relation to the previous diagram, generally atmospheric temperature declines with altitude except where:

- “solar wind” particles are intercepted in the thermosphere which includes the ionosphere.
- incoming solar radiation is absorbed in the stratosphere (in which the ozone layer lies),
and

Measured profile above Tucson Arizona

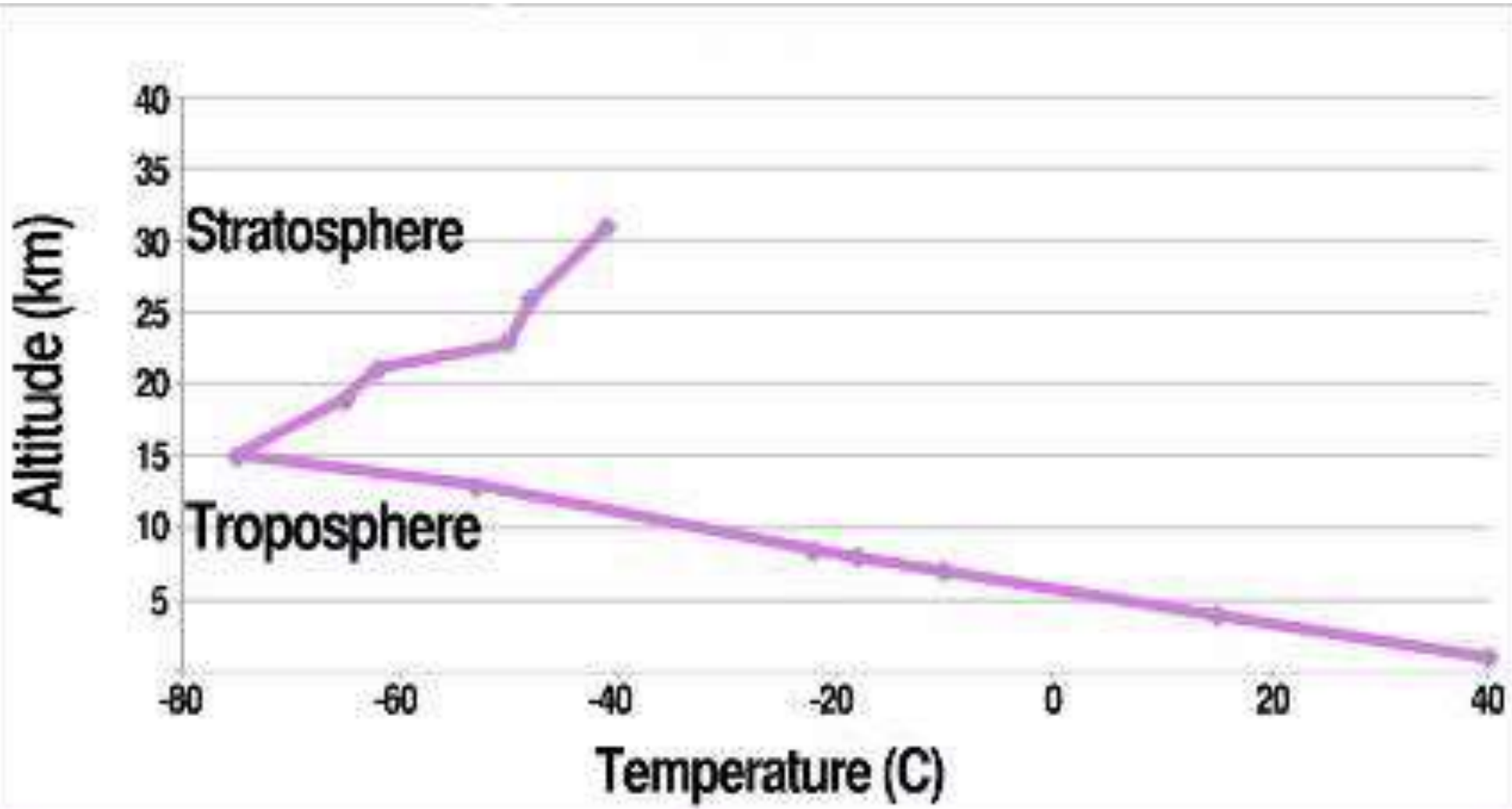

The figure shows the observed atmospheric temperature as a function of altitude over Tucson, AZ, in late afternoon, 14 August 2000, when the surface temperature was 36.7 °C.

The Troposphere

“The troposphere is the lowest region of the Earth's atmosphere, where masses of air are very well mixed together and the temperature decreases with altitude.”

“The air is heated from the ground up because the surface of the Earth absorbs energy and heats up faster than the air. The heat is mixed through the troposphere because on average the atmosphere in this layer is slightly unstable.”

http://www.windows.ucar.edu/tour/link=/earth/Atmosphere/layers_activity_print.html&edu=high

The proposed vortex engine is basically a system to enhance the transmission of energy through the troposphere by convection.

Updraft Clouds



Australian Government

© Copyright Commonwealth of Australia 2006,
Bureau of Meteorology

Bureau of Meteorology

Updraft velocities of up to 240 km/hr. have been recorded - enough to hold hailstones of up to 178 mm diameter aloft.

Atmospheric water vapor should arguably be regarded as a storehouse of solar energy.

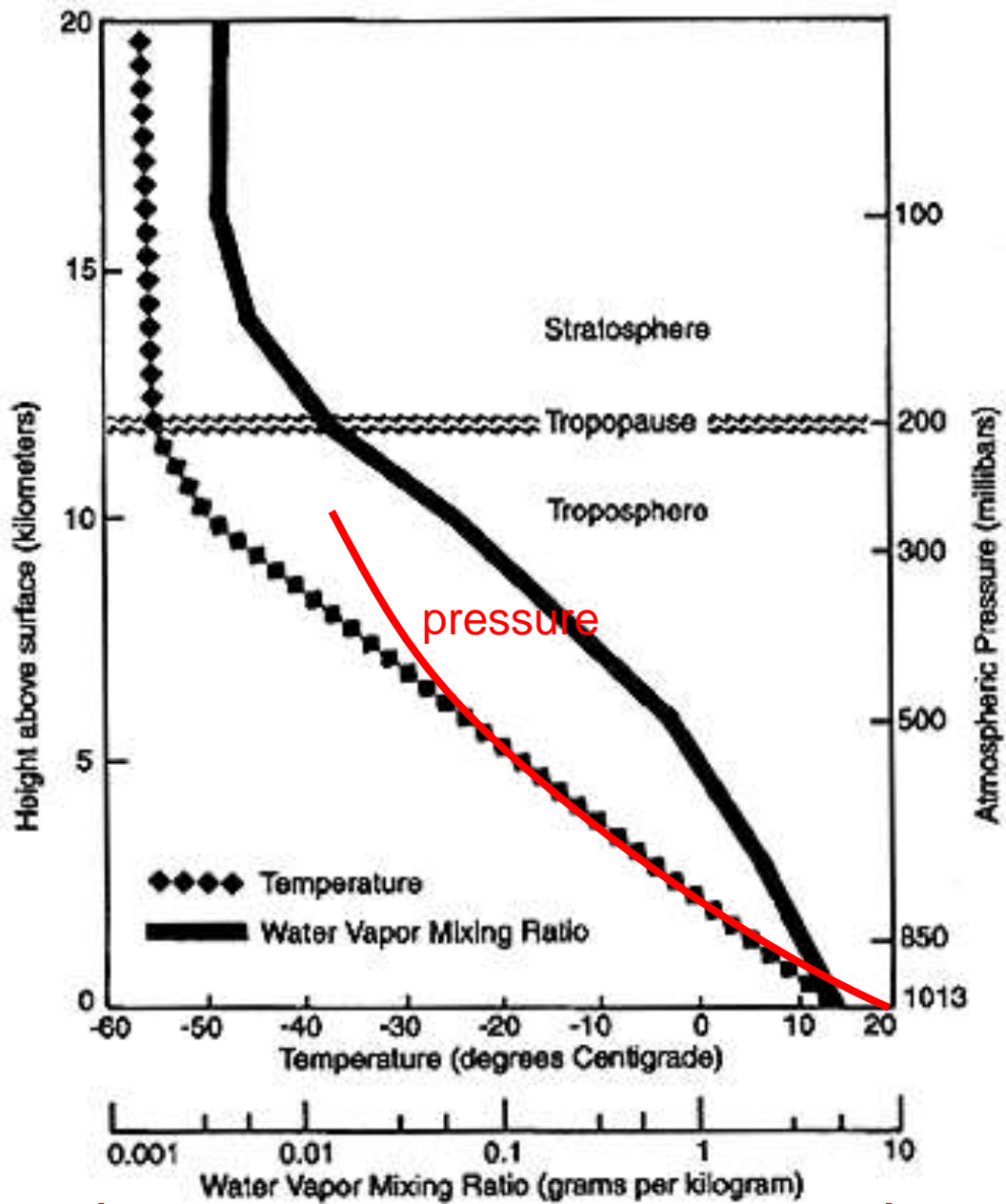

0

100 kPa

Vapour emissions from Industry

Vapour emissions from an alumina refinery



For every tonne of alumina produced, around half a tonne of water vapour is emitted through calcination alone. This amounts to approximately 7 Megatonne per annum in Western Australia.

This also corresponds to around 770 MW of thermal energy, from which the vortex engine should be able to generate 20%, or 150 MWe.

Vapour emissions from 2 GW Loy Yang power station



Water is vaporised a) within the wet cooling towers and b) in the combustion of the 30 Megatonne pa of brown coal which is around 60% water by weight.

The approximate annual vaporisation for cooling tower emissions is 34 Megatonne and 18 Megatonne in combustion of the fuel => **52 Megatonne total**, or $5.7 \text{ GW}_{\text{th}}$.
The vortex engine should be able to generate around 1.2 GWe from this.

Plume energy lost through radiation

Plume energy lost through radiation

$$q = \epsilon \sigma (T_h^4 - T_c^4) A_c$$

where

q = heat transfer per unit time (W)

ϵ = emissivity

σ = Stephan-Boltzmann constant

T_h = hot body absolute temperature (K)

T_c = cold surroundings absolute temperature (K)

A_c = area of the object (m^2)

The emissivity of H₂O and CO₂ are both high, whereas the emissivity of O₂ and N₂ which together make up the majority of gas in the atmosphere, are both very low. Hence an updraft within a vortex can approximate to an adiabatic process.

If the vertical velocity of the updraft is relatively low, water vapour may condense and freeze in the form of mid-level clouds.

For an updraft with ΔT between sea level and tropopause of 100C, and 1% water content, around 20% of the available change in enthalpy comes from water, 80% from the air.

Vortices in Nature

Vortices in Nature

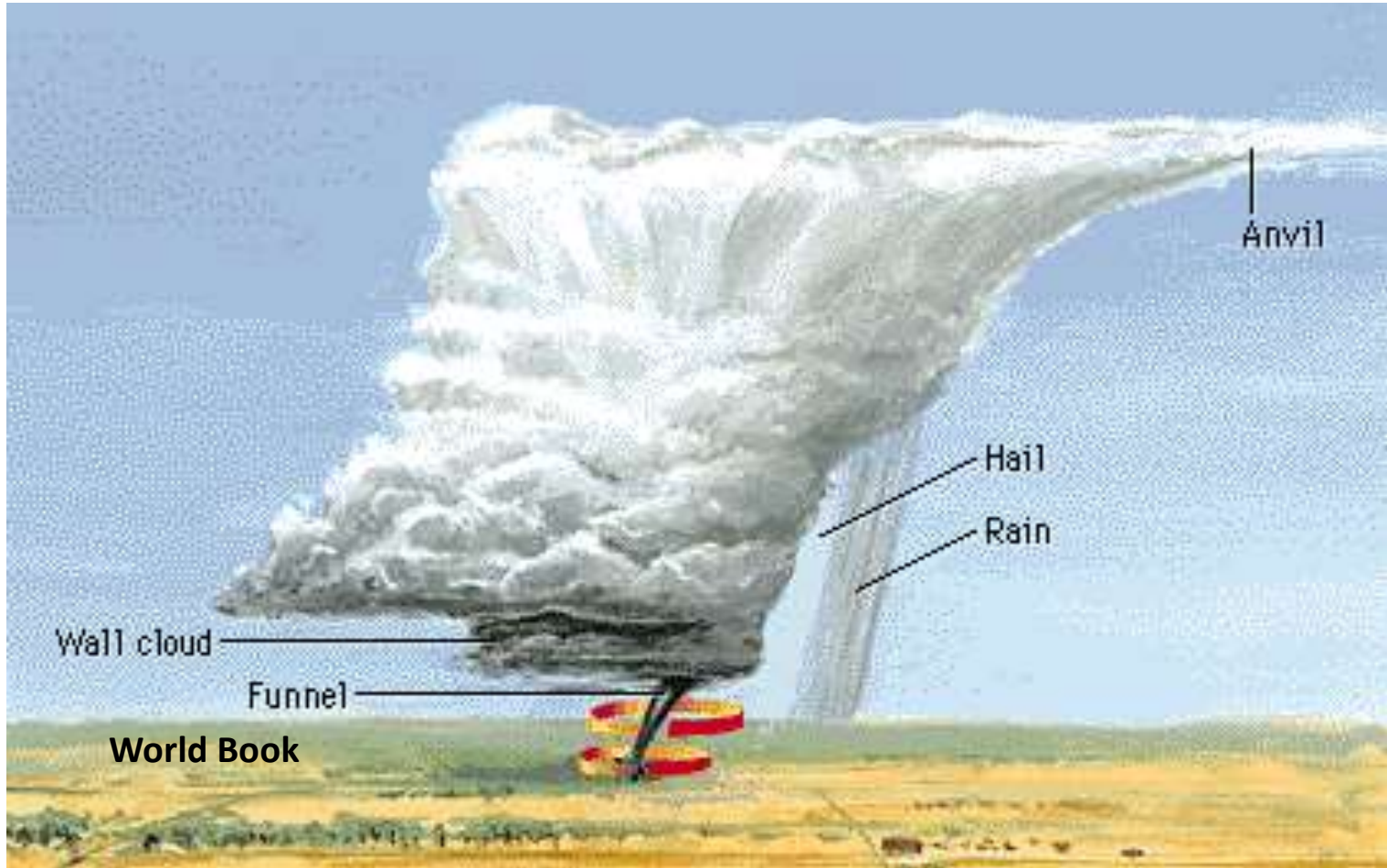

The tornado is a highly effective mechanism through which Nature acts to convey humid boundary layer air to the top of the Troposphere where precipitation is initiated. The “anvil” is formed when it reaches the tropopause (ca. 10 km), the interface with the stratosphere.

Airflow in a vortex at altitude

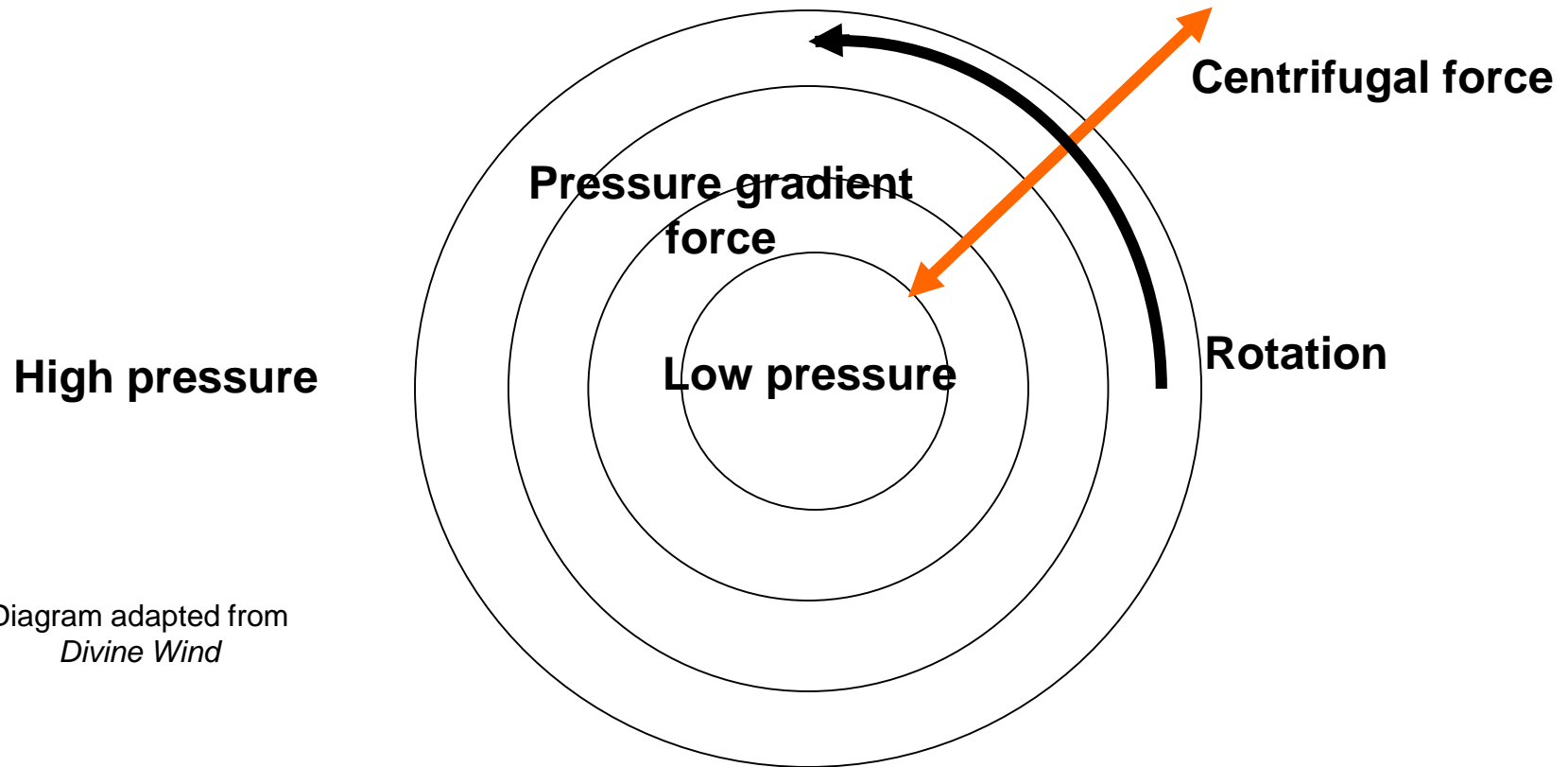

At altitude, the pressure gradient force (inwards) exactly equals the centrifugal force (outwards). Air thus rotates without a significant radial component

Airflow in a vortex near ground level

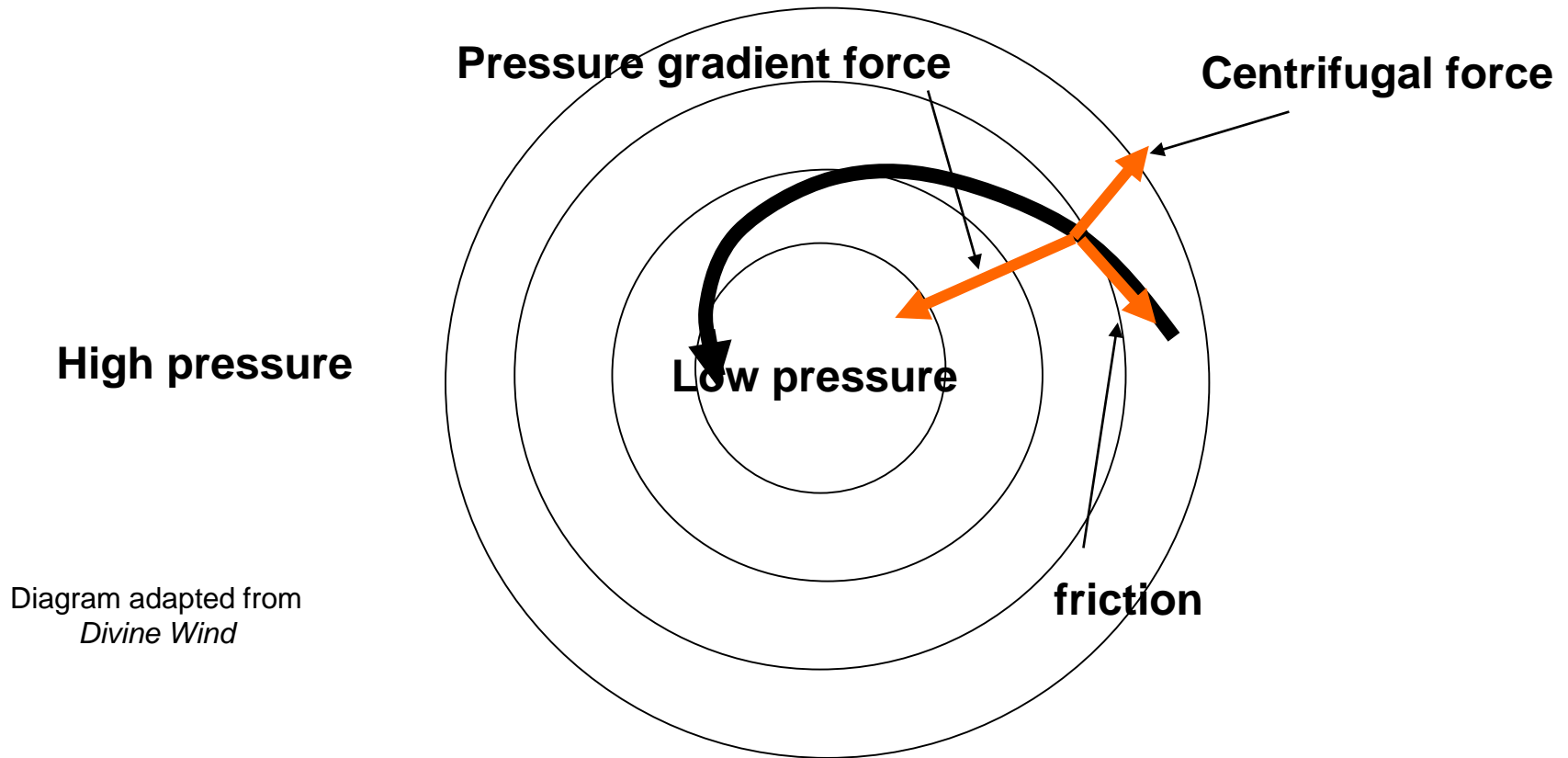

Within the boundary layer, friction acts to reduce the rotational velocity and hence the centrifugal force. The air is consequently able to spiral towards the low pressure at the vortex centre.

The Power Dissipation of Atmospheric Vortices

The powers dissipated by vortices are in the order of:

Tornado	~1 GW
Tropical Cyclone	~3,000 GW
Severe Tropical Cyclone	~30,000 GW

Positive Feedback Within a Vortex

Positive Feedback Within a Vortex

1. Warm air “rises” towards the centre (the eye) of the centrifugal field as it is less dense. It is also more buoyant in the Earth’s gravitational field and hence rises vertically when it reaches the eye.
2. Atmospheric water vapour, which has a mass density about 63% that of air at the same temperature and pressure, is also displaced towards the centre of the centrifugal field and rises vertically once in the eye.
3. Centrifugal force reduces the pressure at the centre of the centrifugal field. Low pressure again means low density and hence high buoyancy. A buoyant gas has inherent potential energy.
4. As the air/vapour mixture progresses to the low-pressure eye, some water vapour condenses, releasing latent heat. **The typical tornado “funnel” is visible because of the condensed water particles.**

Each of the above processes acts to create a strongly buoyant updraft within the eye and hence a self-sustaining natural “chimney” effect.

Just as the potential energy of elevated water can be harnessed to drive hydroelectric turbines, so too the potential energy of a warm air/vapour mixture can drive wind turbines.

Precipitation efficiency vs altitude

Precipitation Efficiency (ϵ_p) vs. Cloud Height

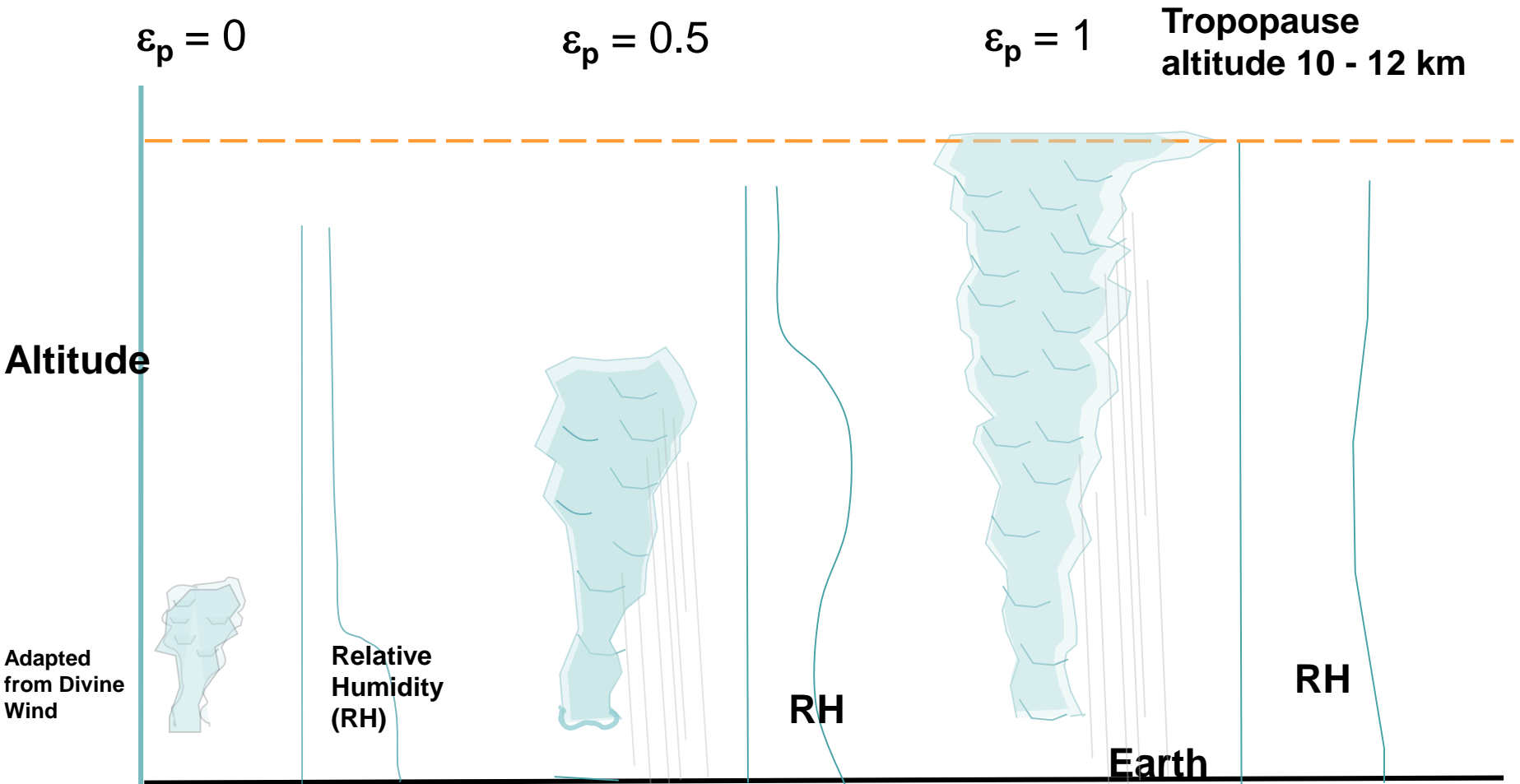

When clouds reach the top of the Troposphere, precipitation efficiency tends towards unity. Some evaporation occurs during the descent of the rain, but this is not an entire loss as the evaporation causes cooling of the surrounding air, subsequent downdrafts, and horizontal wind when the flow hits the ground. Some of this energy can be harvested by means of conventional wind turbines.

The Carnot Engine

A Tropical Cyclone seen as a Carnot Cycle

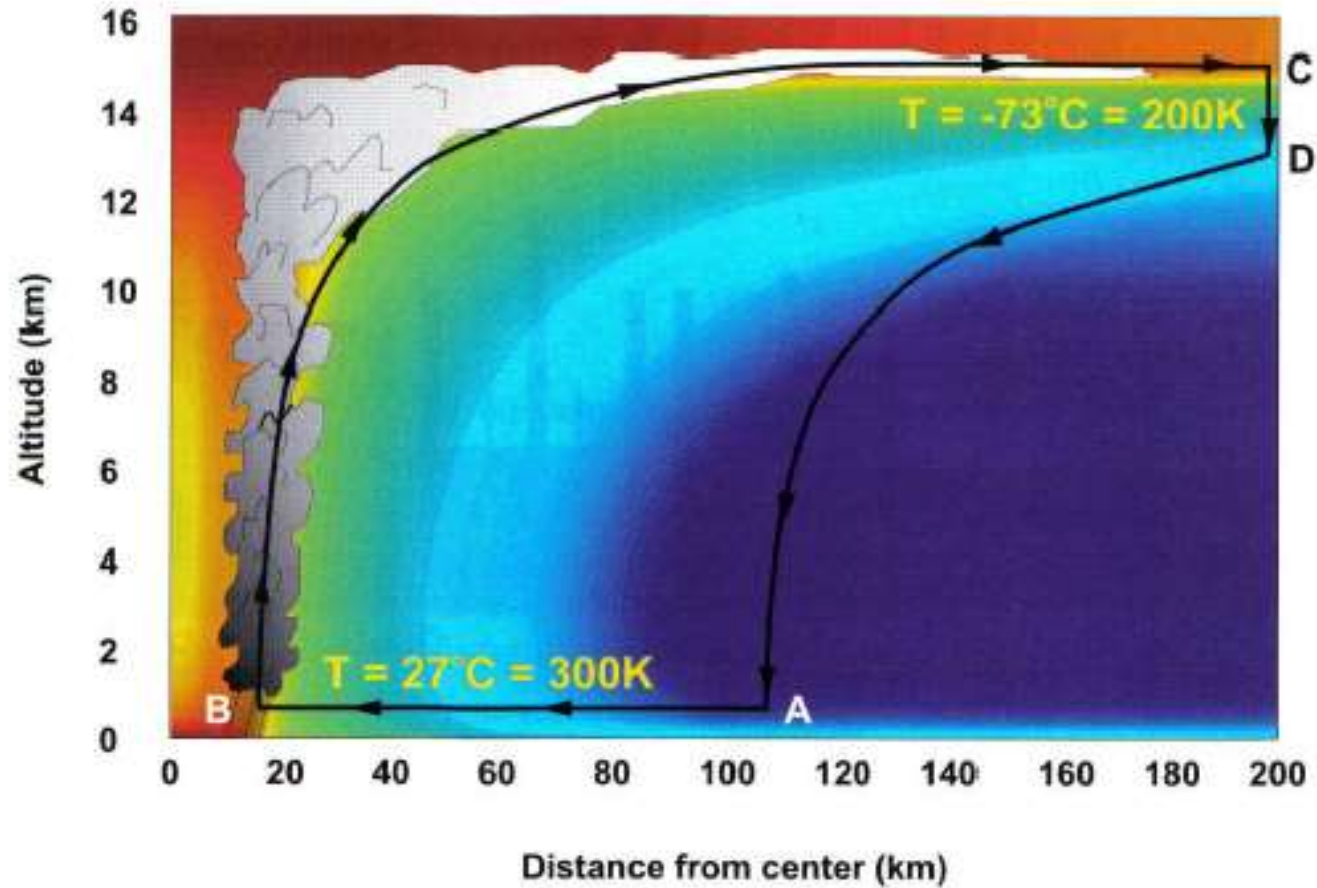

Efficiency

$$n = 1 - T_c / T_h = 1 - 200/300 = 33\%$$

(The colour coding indicates zones of equal entropy)

The Carnot Engine

The Carnot cycle has the equal highest possible theoretical efficiency of any thermodynamic cycle, but has not been practicable for use in mechanical heat engines.

The ideal thermodynamic efficiency of a Carnot cycle is a function of difference between the extreme temperatures of the cycle. The relationship between efficiency and temperature difference is given by

$$\eta = \frac{T_h - T_c}{T_h}$$

Where T_h = maximum cycle temperature (K)

T_c = minimum cycle temperature (K)

Hence for a cycle temperature range 80°C maximum to -70°C minimum, the ideal Carnot thermodynamic efficiency would be :

$$\begin{aligned}\eta &= \frac{150}{353} \\ &= 0.42 \\ &= 42\%\end{aligned}$$

The GaTech project

Georgia Institute of Technology presentation summary

<http://arpa-e.energy.gov/?q=slick-sheet-project/power-generation-using-solar-heated-ground-air>

Quote:

“Georgia Tech is developing a method to capture energy from wind vortices that form from a thin layer of solar-heated air along the ground. “Dust devils” are a random and intermittent example of this phenomenon in nature. Naturally, the sun heats the ground creating a thin air layer near the surface that is warmer than the air above. Since hot air rises, this layer of air will naturally want to rise.

The Georgia Tech team will use a set of vanes to force the air to rotate as it rises, forming an anchored columnar vortex that draws in additional hot air to sustain itself. Georgia Tech's technology uses a rotor and generator to produce electrical power from this rising, rotating air similar to a conventional wind turbine.

This solar-heated air, a renewable energy resource, is broadly available, especially in the southern U.S. Sunbelt, yet has not been utilized to date. This technology could offer more continuous power generation than conventional solar PV or wind. Georgia Tech's technology is a, low-cost, scalable approach to electrical power generation that could create a new class of renewable energy ideally suited for arid low-wind regions.”

If successful, Georgia Tech's technology would reduce the cost of energy by 20% over wind power and 65% over solar photovoltaic energy.

“Reap the whirlwind for cheap renewable power” (cont’d)

“The US government's clean energy start-up shop is convinced: the Advanced Research Projects Agency Energy (ARPA-E) announced its decision to fund some large-scale trials last week. Simpson is due to present a paper in July detailing the trials at the *ASME International Conference on Energy Sustainability* in Minneapolis, Minnesota. Working with ARPA-E, Simpson and Glezer plan to have a 10 kW model running within two years, with tests on intermediate models scheduled for July. They want to build a 50kW model in the future.”

“ ‘The science is solid,’ says Nilton Renno, who researches thermodynamics at the University of Michigan. ‘Once you induce circulation nearby, the vortex can be self-sustaining.’ ”

“Steven Chu, the outgoing Energy Secretary, is interested; he visited the team briefly at the ARPA-E conference in Washington DC last week. ‘We would like to start with building a small-scale farm of these things,’ Simpson says. ‘At that point we start to produce real energy, and can begin to sell some of that energy and convince people of our system.’ ”

GATECH research project participants:

- Georgia Institute of Technology
- University of Illinois, Urbana Champaign
- University of Texas, Austin

- United Technologies Research Center

- National Renewable Energy Laboratory
- ARPA-E (funder)

GATECH Quote:

“Recent outdoor tests of a meter-scale prototype coupled with a simple vertical-axis turbine placed on a surface directly heated by solar radiation, have demonstrated **continuous rotation of the turbine with significant extraction of kinetic energy from the column vortex, in both the absence and presence of crosswind.**”

The eventual full-scale Gatech proposal envisages a vortex with a 50 metre diameter core.

The Solar Vortex (SoV) Power Generation Concept

- Novel, low-cost, scalable method to harness vast amounts of low-grade thermal energy in the natural environment, for sustainable electricity production using a **solar-induced convective wind field**.
 - » 'Green,' renewable, reduces emissions, improved power generation efficiency, enhanced energy security.
- Naturally heated air layers occur near sun-warmed ground (nominally at $0.5\text{-}1\text{ kW/m}^2$).
 - » In both arid and humid environments.
- **GOAL:** extract energy by exploiting thermal stratification set by temperature difference between the air and the warmed ground.
 - » Significant air motion is typically induced by spontaneous, buoyancy-driven "dust devils" columnar vortices.
- **APPROACH:** generate power by deliberately forming and anchoring intense columnar vortices with each vortex driving a vertical-axis turbine coupled to an electric generator.

Array

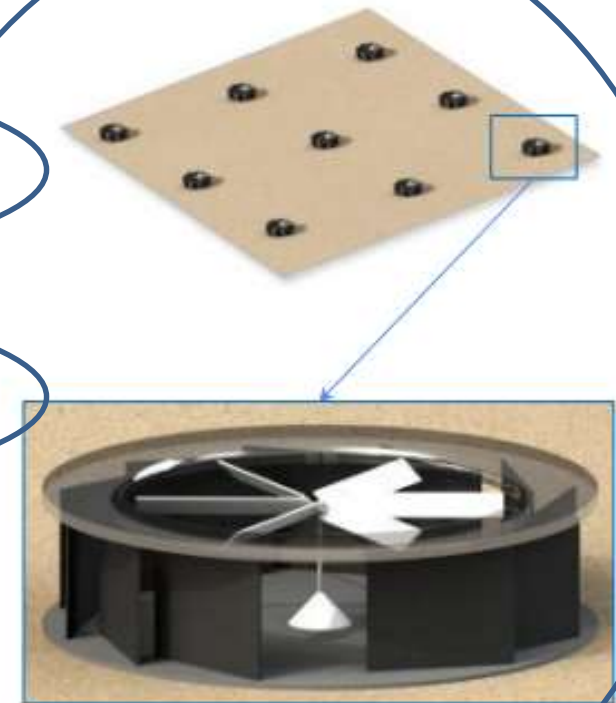

Gatech

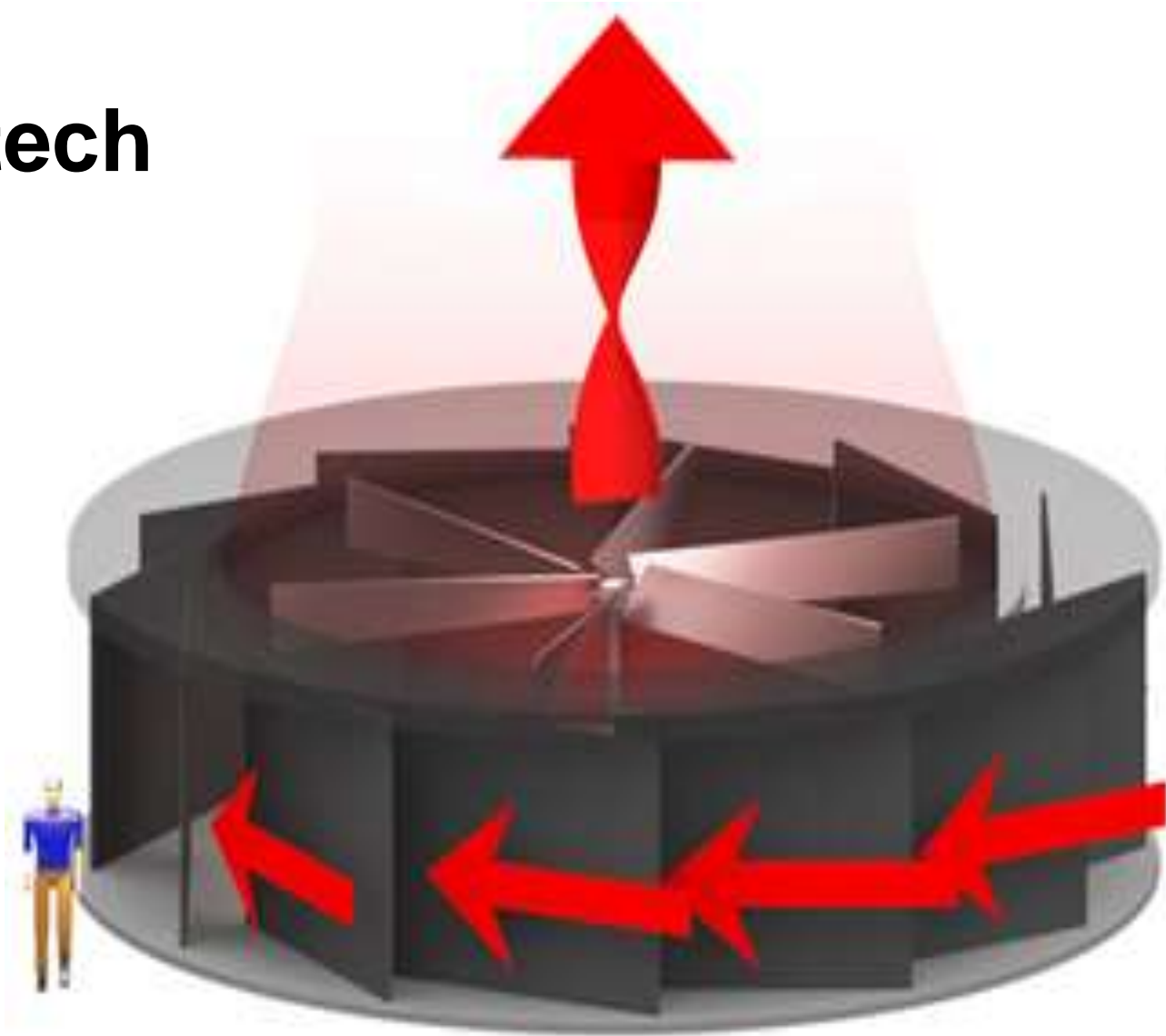
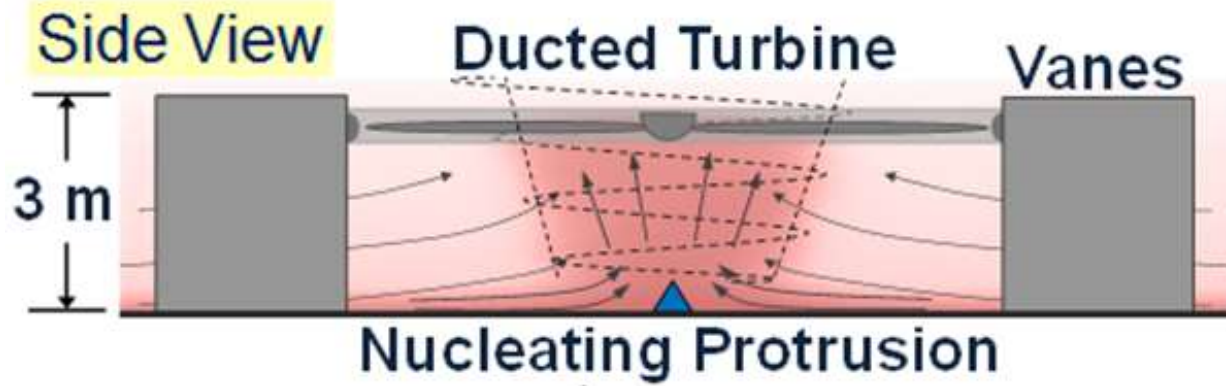
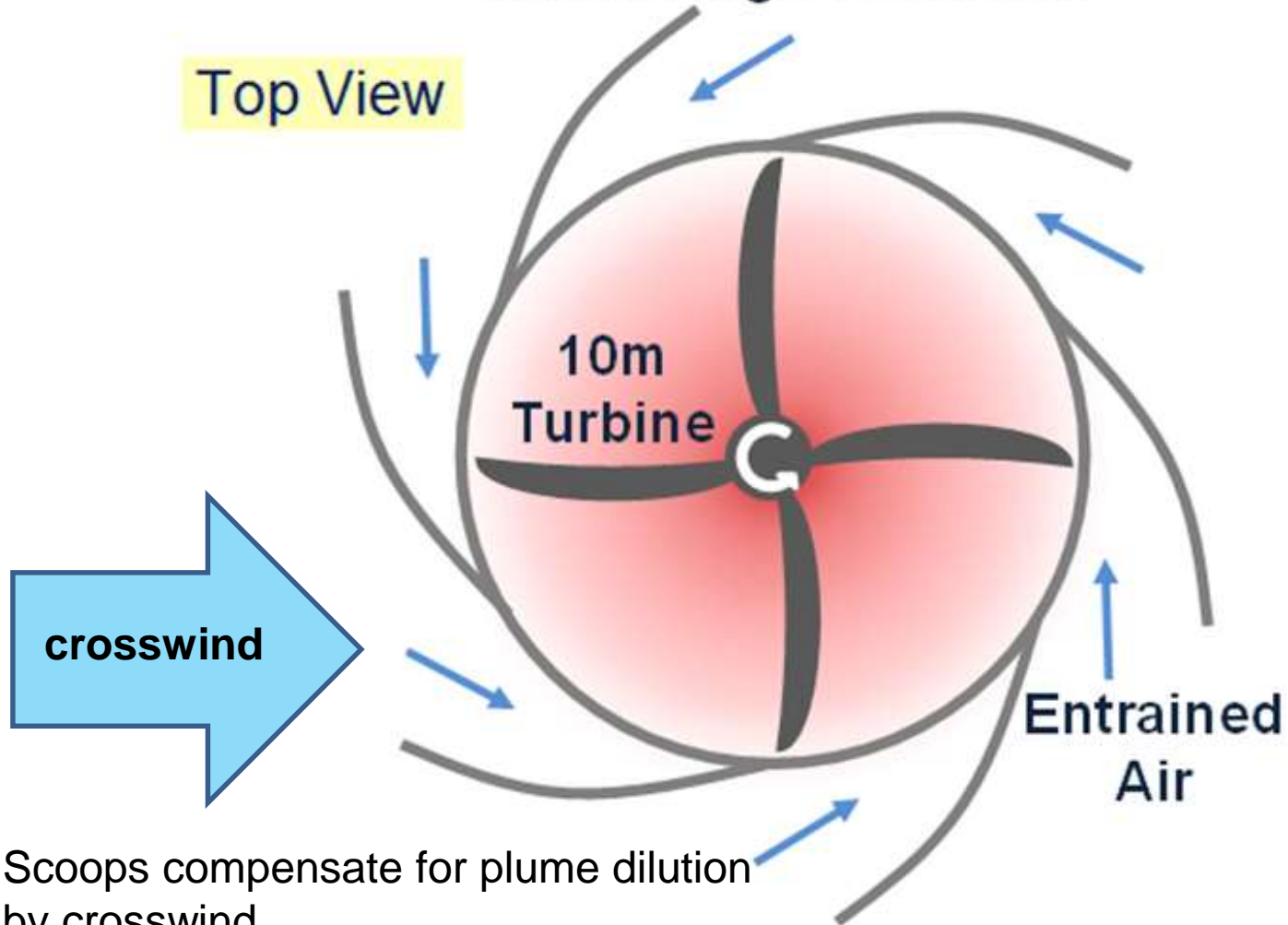

Diagram of standard Module 10 m diameter, 3 m high



Top View



Scoops compensate for plume dilution by crosswind

Preliminary SoV LCOE Analysis

- **First Cost:** Preliminary analysis shows 35% reduction in first cost over wind due to elimination of tower and reduced component costs.
- **Cost of Energy:** The Solar Vortex has the potential to reduce LCOE by 20-65% over wind and solar, creating a competitive new class of renewable energy for the U.S sun belt.

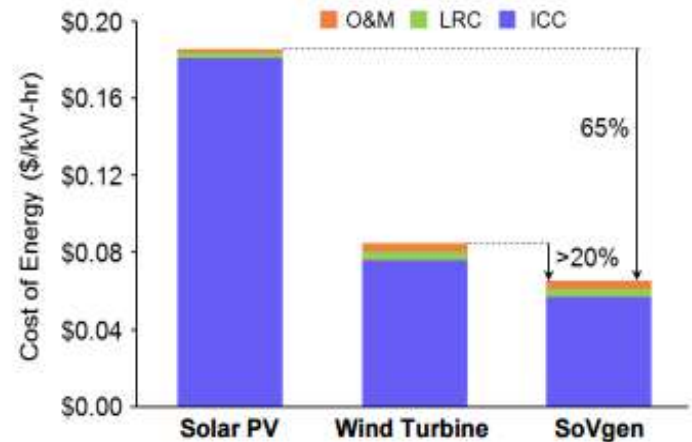
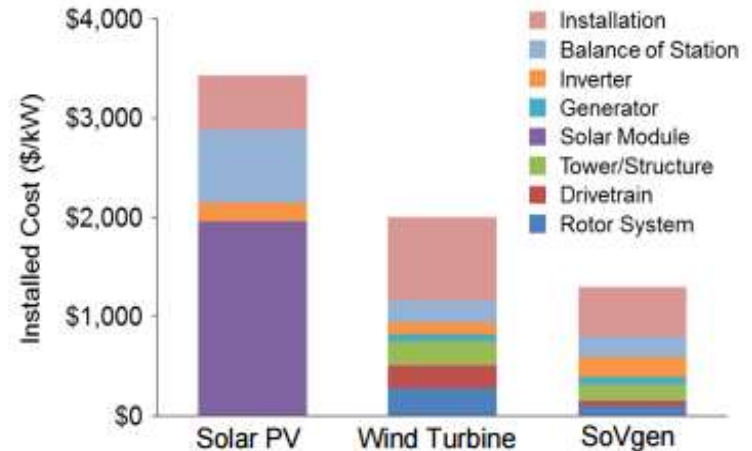

General:

Atmospheric water vapour content

Specific Water Vapour Content

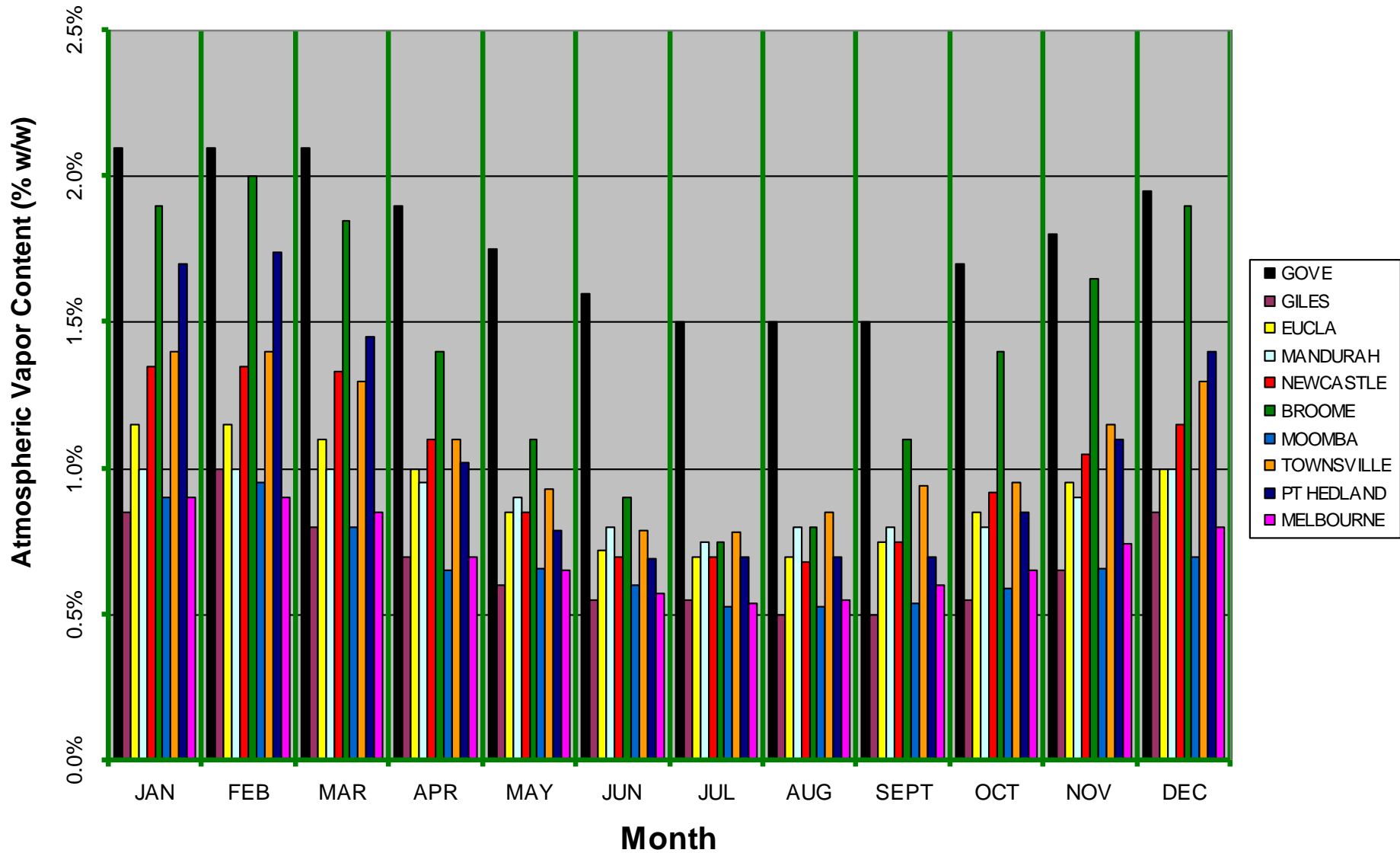

Relative Humidity vs. Absolute Water Content

The desert air has a low **relative humidity**, but the much more important **absolute moisture content** can be comparable to that of cooler, more temperate regions.

Notice that the absolute moisture content of the air is lower in winter than in summer. This is initially counterintuitive.

Atmospheric Water Content

- It has been estimated that only 2% of the atmospheric water content is in the form of clouds. The remaining 98% is in the form of water vapour.
- At 1% average water content, the lowest one kilometre of the atmosphere above the Australian continent contains in the region of 100 billion tonnes of water.
- The flow of water through the atmosphere is coming to be recognized as “flying rivers.”

Geothermal energy

Geothermal Energy “Priming” of the Vortex Engine

Vortex Engines will have to be located, initially at least, far from population centres. There will be a powerful “not in my back yard” effect.

Geothermal energy is therefore an excellent candidate to prime the vortex engine process.

The Atmospheric Vortex Engine can work satisfactorily with *low grade* geothermal energy (<100°C), whereas typical Rankine cycle power plant requires temperatures above 200°C.

Hot sedimentary aquifers such as those of the Great Artesian basin and Otway basin are arguably the best sources for vortex engine priming energy as they have the advantage of being easily tapped with well-proven technology.

The Birdsville geothermal power station plant derives its energy from the near-boiling (98°C) water taken from the Great Artesian Basin at a relatively modest depth of 1230m.

Geothermal Energy Economics

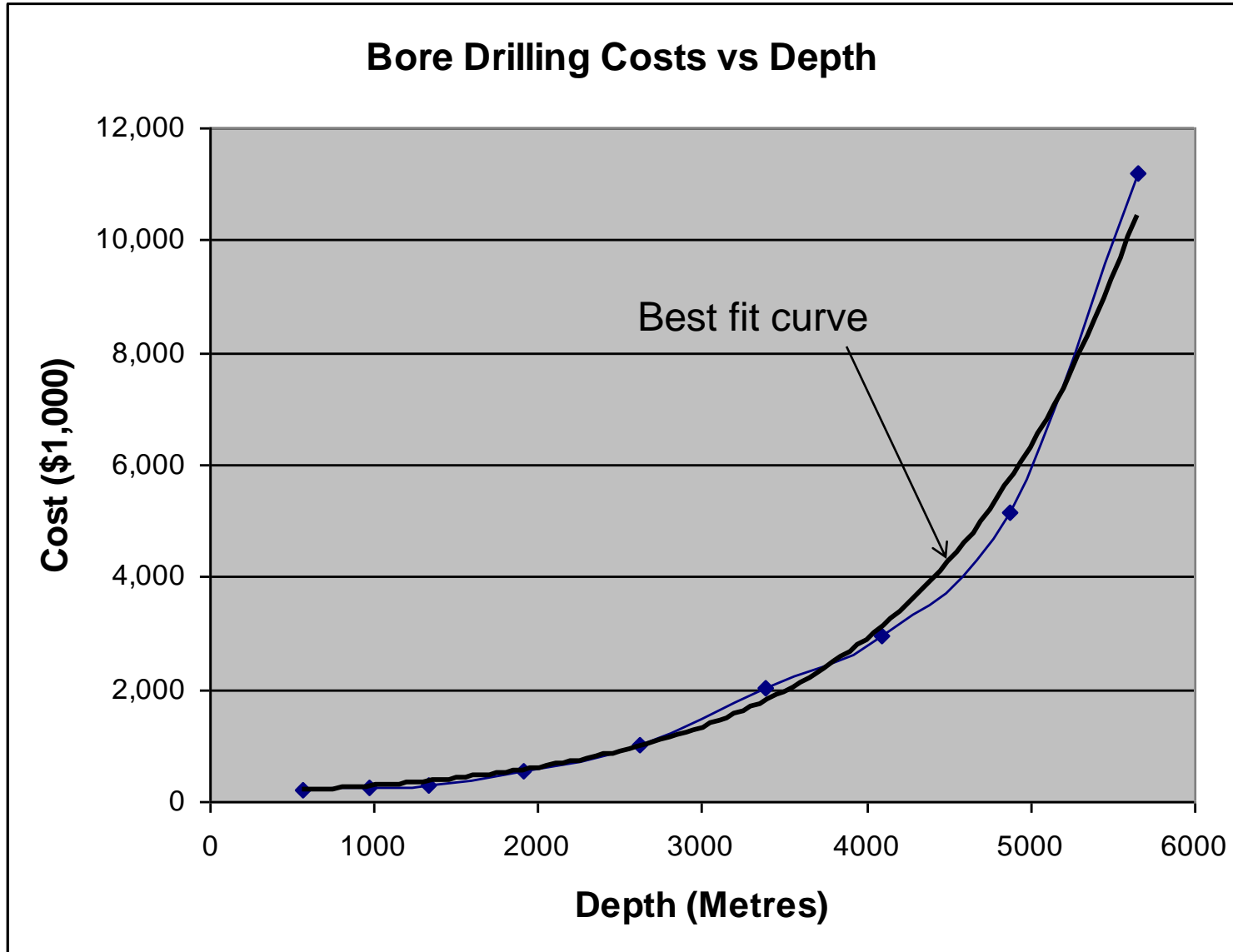

(source: A Comparison of Geothermal with Oil & Gas Well Drilling Costs – MIT Feb 2006)

From the drilling cost graph, it can be seen that because of the power law on the drilling cost curve, the economics are radically improved by using shallower bores. Alternatively an otherwise uneconomic geothermal field can be tapped closer to the end use point, dramatically reducing transmission costs. For instance the Cooper basin field in Australia is around a thousand kilometres from the end use point. Transmission capital costs are typically in the order of \$1 million per kilometre, hence adding around \$1 billion to the cost of a typical power station.

It should be noted that drilling costs are expected to be very substantially reduced with the development of new drilling technologies.

In the worst case, the infrastructure cost of geothermal priming energy for a 1 GW system (~200 MWe output) could be in the region of \$100 million. Note that the geothermal energy does not have to meet the whole energy input, as there is a significant level of enthalpy available in the atmosphere, even in winter (see slide 45).

In a less optimal geothermal region, the cost could be higher, but the power transmission cost would normally be much lower. New drilling methodologies are being developed which promise to very significantly reduce the cost of deep drilling.

Precipitation

How much precipitation can be expected?

A 200 MW_e vortex engine is expected to generate around 12 thousand tonnes of precipitation per day, assuming 1% atmospheric water content and evaporation losses of up to 50% in falling to earth.

If the vortex engines were installed at 10 km centres, this would theoretically yield around 50 mm per annum. There is some reason to believe this may be amplified by natural processes =>>

Flying Rivers



Sunlight pours around a "flying river"— a vast, humid air current over the Amazonian rain forest

Photograph courtesy Gérard Moss, Flying Rivers Project

Forest Rainfall Generation

Biotic pump

A controversial theory could explain how large volumes of water reach thousands of kilometres inland

Water vapour over coastal forests condenses to form droplets and clouds. This lowers local air pressure and sucks in moist air from the ocean

If coastal forests are cut, the winds reverse



On a large continent with a forested coast, the rain exported inland helps the forest expand. This process repeats itself, sustaining forest right into the continent's heart

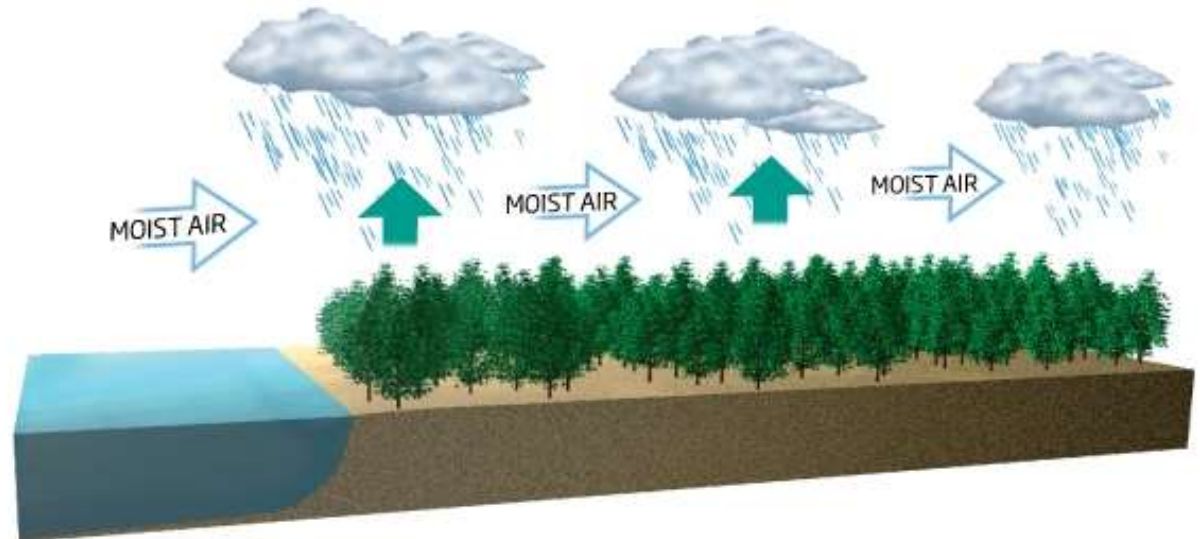

Forest Rainfall is Related to the Vortex Engine Precipitation

“...How can forests create wind? Water vapour from coastal forests and oceans quickly condenses to form droplets and clouds... the gas [from this evaporation] takes up less space as it turns to liquid, lowering local air pressure. Because evaporation is stronger over the forest than over the ocean, the pressure is lower over coastal forests, which suck in moist air from the ocean. This generates wind that drives moisture further inland. The process repeats itself as the moisture is recycled in stages, moving towards the continent’s heart. As a result, giant winds transport moisture thousands of kilometres into the interior of a continent.

The volumes of water involved in this process can be huge. More moisture typically evaporates from rainforests than from the ocean. The Amazon rainforest, for example, releases 20 trillion litres [20 billion tonnes] of moisture every day.

‘In conventional meteorology the only driver of atmospheric motion is the differential heating of the atmosphere. That is, warm air rises,’ Makarieva and Gorshkov told New Scientist. But, they say, “Nobody has looked at the pressure drop caused by water vapour turning to water...”

New Scientist 01 April 2009

Refer also: ***Precipitation on land versus distance from the ocean: Evidence for a forest pump of atmospheric moisture***; A.Makarieva, V.Gorshkov and Bai-Lian Li; ScienceDirect 10 Jan 2009.

We are Turning the Amazon into a Desert!

<http://blog.cifor.org/26559/the-science-is-clear-forest-loss-behind-brazils-drought?fnl=en>

The science is clear: Forest loss behind Brazil's drought

http://www.theecologist.org/News/news_analysis/2776099/without_its_rainforest_the_amazon_will_turn_to_desert.html

Without its rainforest, the Amazon will turn to desert

60% OF EARTH'S HEAT TRANSFER TO SPACE TAKES PLACE THROUGH MOIST CONVECTION

http://www.atmos.washington.edu/~dargan/587/587_3.pdf

The rabbit-proof fence in Western Australia was completed in 1907 and stretches about 3,000 km. It acts as a boundary separating native vegetation from farmland. Within the fence area, scientists have observed a strange phenomenon: above the native vegetation, the sky is rich in rain-producing clouds. But the sky on the farmland side is clear.

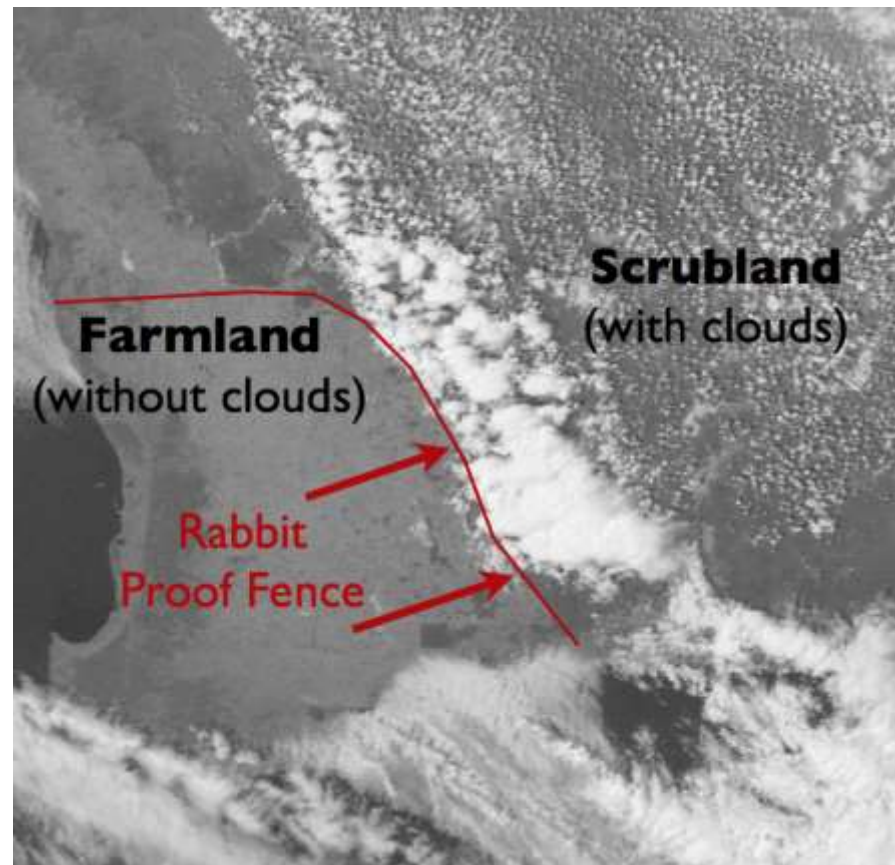

Evaporation of Water at the Sea–Atmosphere Interface

The vortex engine is theoretically most effective near the equator, due to a combination of high temperatures and humidity.

To enable the Vortex Engine to achieve maximum efficiency at mid to higher latitudes, local humidity has to be increased. Others have looked at this before:

...However the evaporation of water from the sea surface is slow and inefficient because of the need for large amounts of latent heat and because the perpendicular component of turbulence in the air vanishes at the surface leaving a stagnant humid layer (Csanady 2001). The wind has to blow over thousands of kilometres of warm sea before it can bring rain. Saudi Arabia is dry because the Red Sea and the Persian Gulf are narrow. Chile is dry because the Humboldt current is cold...

<http://www.mech.ed.ac.uk/research/wavepower/rain%20making/shs%20rain%20paper%20Feb.pdf>

The proposed mechanism to attain this is shown in the next slide.

Evaporation of Seawater at Coast

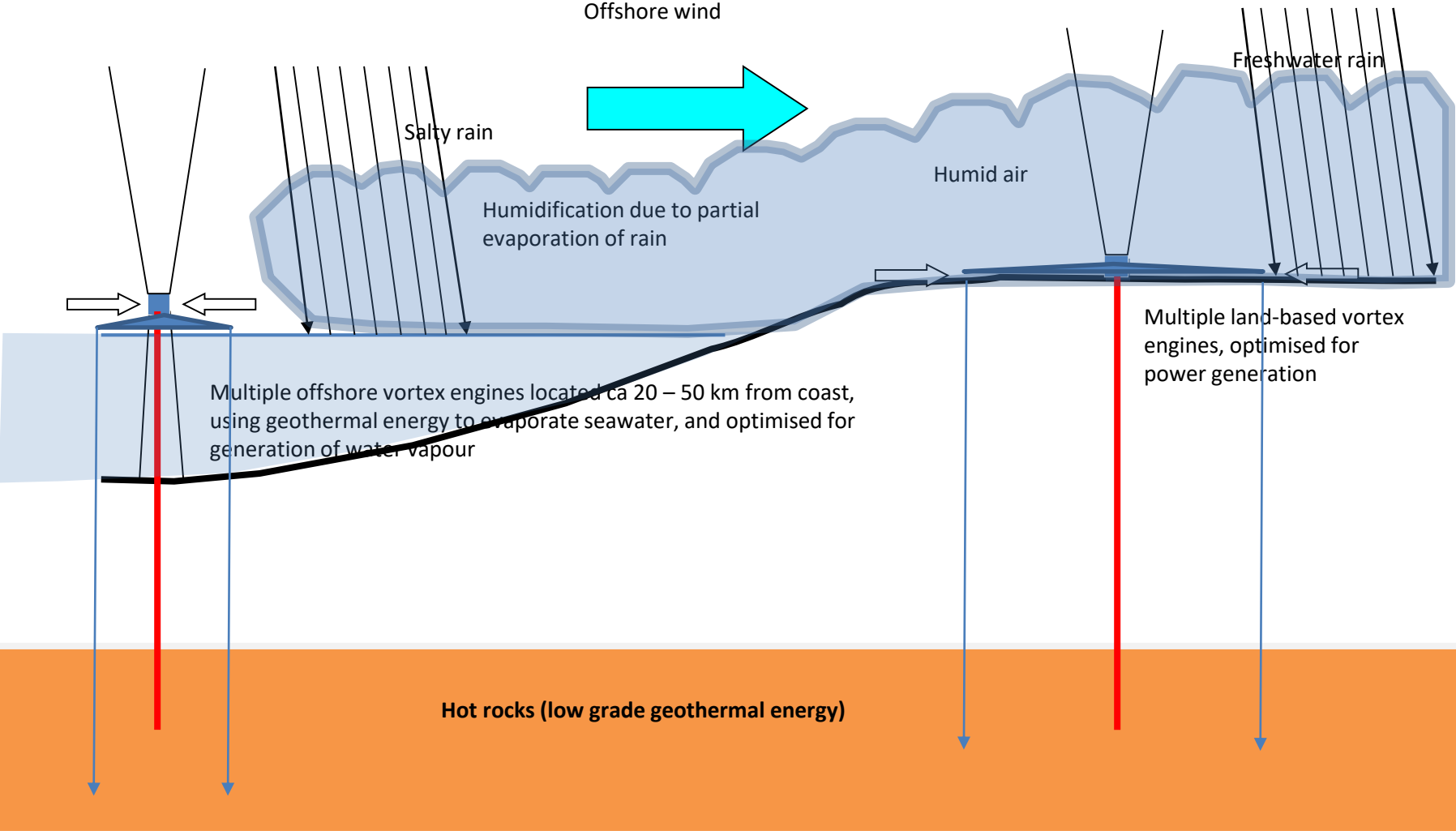

The Desertification of Australia

There is evidence that the desertification of much of Australia coincided with the replacement of fire-tender rainforest with fire-resistant sclerophyll forest about a hundred thousand years ago. This may have been due to increased lightning strikes with climate change, or the arrival of Man:

“For a specific example Makarieva and Gorshkov point to prehistoric Australia. They believe the pump ‘explains the enigmatic conversion of Australian forests to deserts that roughly coincides in timing with the appearance of the first people.’ ”

“According to Makarieva and Gorshkov, when these early peoples burned small bands of forests along the coast where they first inhabited, ‘The internal inland forests were cut off from the ocean (the tube of the pump cut off) and underwent rapid desertification.’ ”

“Simply put a loss of coastal forests—which had been driving rain from the ocean into the interior—caused Australia's current dry climate. If Australia hadn't lost those coastal forests, its environment may be entirely different today—and would not be suffering from extreme and persistent droughts.”

Source: Mongabay.com, 1 April 2009

The Desertification of Australia

This thesis is supported in **Fire: The Australian Experience** :

“Some scientists believe that this dramatic increase in charcoal is due to fires deliberately started by people, and that the changes in vegetation cannot be explained just in terms of climate changes. This is because, at this site, there had been little change in vegetation before this, despite significant fluctuations in climate in North Eastern Australia. In addition to this there was a continuous charcoal record throughout all samples, indicating that there would always have been some naturally occurring fire in the environment and this also had little effect on the environment. Evidence of this kind has been used to support the theory that Aborigines were living in Australia well before the generally accepted figure of 40,000 years ago.”

http://www.rfs.nsw.gov.au/file_system/attachments/State/Attachment_20050308_44889DFD.pdf

Also see **Arid Australian interior linked to landscape burning by ancient humans**
http://www.eurekalert.org/pub_releases/2005-01/uoca-aa1012505.php

Early Man can be excused because of ignorance, but today we know what we are doing. Thus rainforests such as those of Amazonia and Borneo may also be vulnerable to destruction by the actions of Man: see the details in

<http://www.unep.org/pdf/GEOAMAZONIA.pdf> .

This report discusses the future of the Amazon, including the potential impact of climate change. It warns that the combination of climate change and deforestation for farming could destroy half the Amazon within 20 years.

Enhanced Precipitation over Land

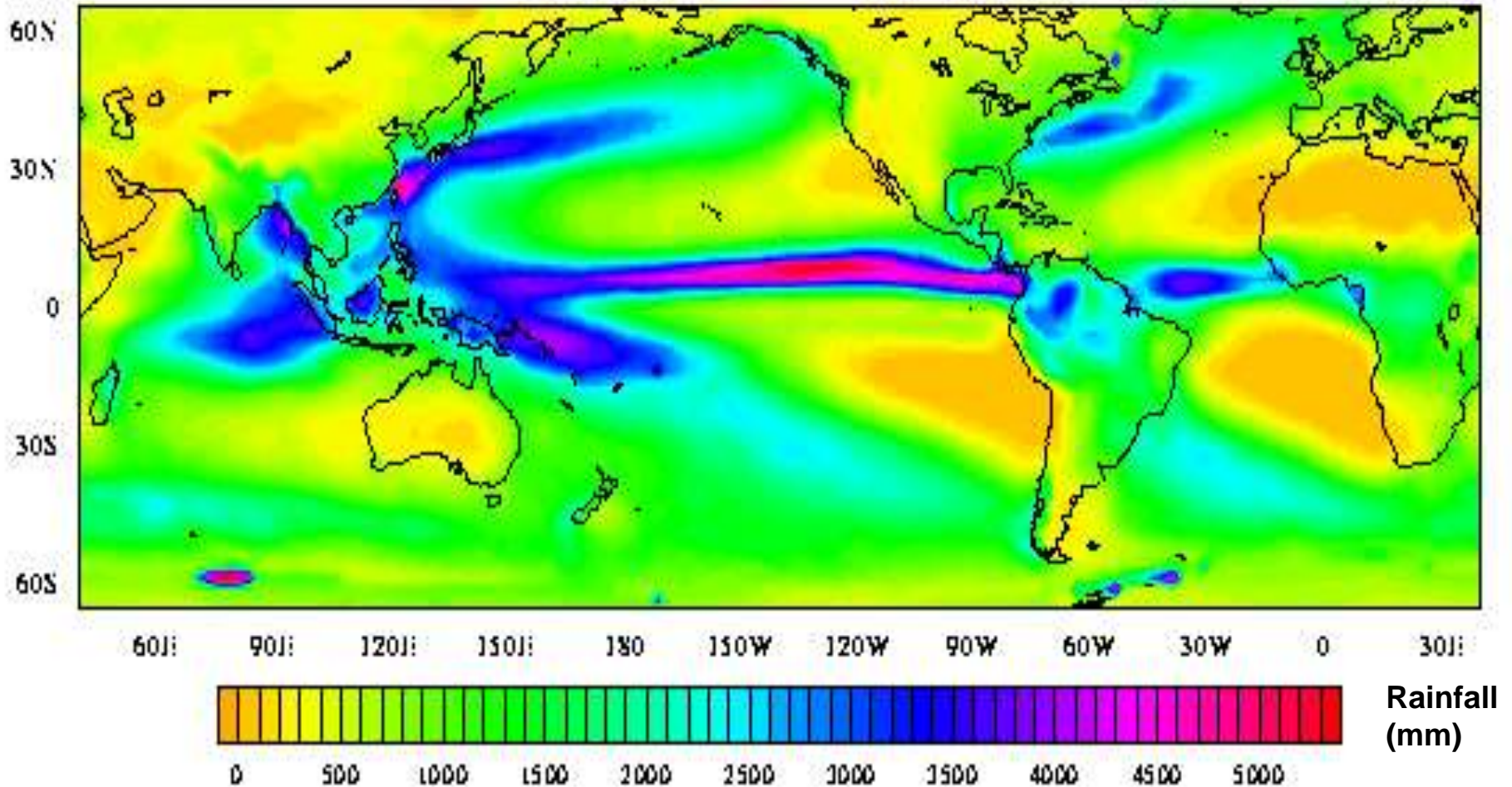

The use of vortex engines cannot increase global precipitation, but in conjunction with forests, it should be able to enhance its distribution. It can be seen above that maritime regions are currently strongly favoured.

Peak Water

The concept of peak oil is well known. Somewhat less well known is that fact that we are “mining” fresh water supplies much faster than they can be replenished:

“...In some regions, water use exceeds the amount of water that is naturally replenished every year. About one-third of the world’s population lives in countries with moderate-to-high water stress, defined by the United Nations to be water consumption that exceeds 10 percent of renewable freshwater resources. By this measure, some 80 countries, constituting 40 percent of the world’s population, were suffering from water shortages by the mid-1990s (CSD 1997, UN/WWAP 2003). By 2020, water use is expected to increase by 40 percent, and 17 percent more water will be required for food production to meet the needs of the growing population. According to another estimate from the United Nations, by 2025, 1.8 billion people will be living in regions with absolute water scarcity, and two out of three people in the world could be living under conditions of water stress (UNEP 2007)....”

From M.Palaniappan and P.H. Gleick in <http://www.worldwater.org/data20082009/ch01.pdf>, 2006.

We have a vicious circle in that population pressures are causing deforestation and hence degradation of the “forest pumping” effect. The vortex engine can help to “kick start” this process again.

Infra red absorptivity

The Vapor Field as Solar Collector

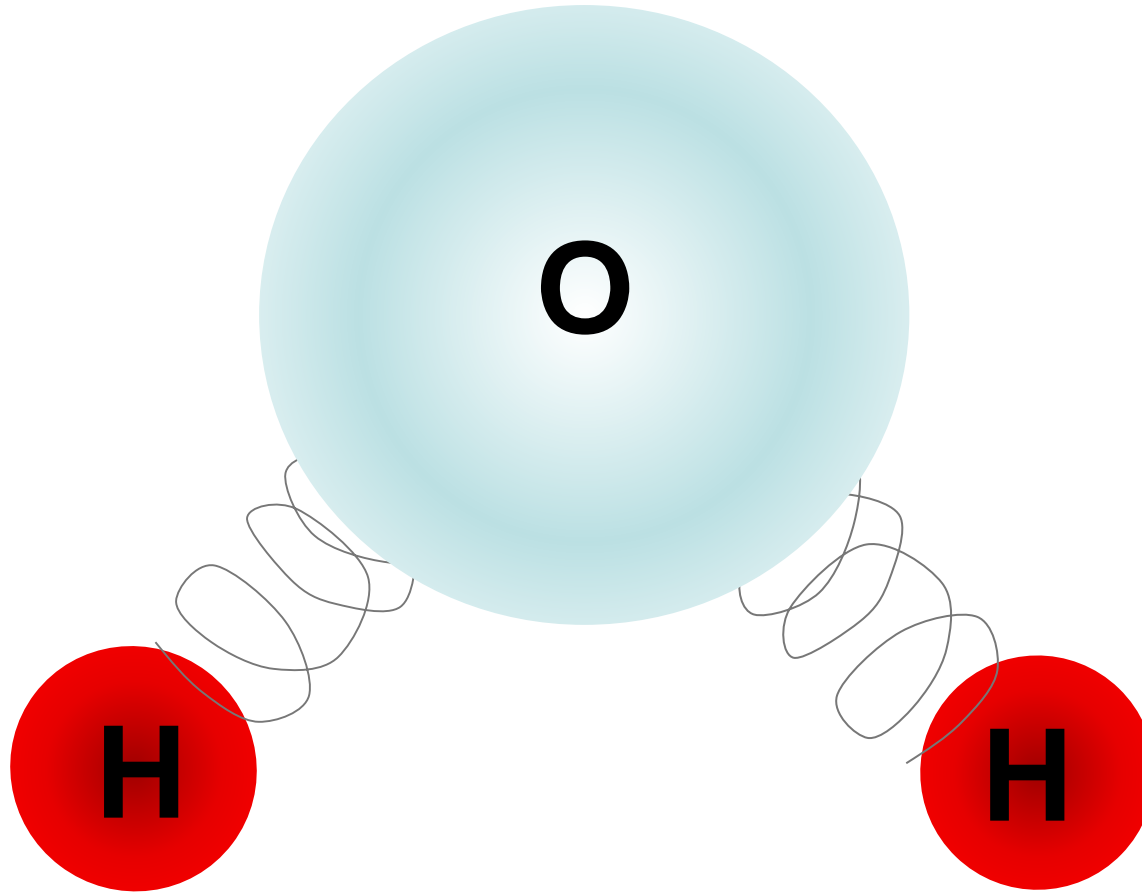

Multi-atomic molecules such as carbon dioxide and water vapor are efficient absorbers of infra-red radiation

Absorption of Infra-Red Radiation

“...compared to molecular nitrogen and oxygen, water vapor molecules are capable of great gymnastic feats. Besides being able to stretch and compress, they can bend at their mid-sections, rotate, and perform combinations of stretching, bending and rotating. Because they can move in such complex ways, they can absorb and emit much more radiation than molecules that consist of only two atoms... Changes in energy state of a single molecule are communicated to neighboring molecules with which it collides... Absorption of radiation... increases air temperature...”

Professor Kerry Emanuel MIT

Thus the water and vapour field associated with a large forest is an efficient solar collector in its own right. The solar energy is stored as the high enthalpy inherent in warm humid air. Most of this enthalpy is in the form of the latent heat of vaporisation of water, and this energy can be utilized within the vortex engine. Hence the engines should ideally be utilized synergistically with forests, helping to modify the local, and on a large enough scale global, climate.

FAQs

What are the advantages of Convective Vortex Systems?

- Reduced CO₂ emissions
- Zero fossil fuel use – instead utilization of stored solar energy within atmospheric water vapour and air
- Increased precipitation over land means increased plant growth and subsequent photosynthesis – hence natural sequestration of CO₂
- Increased heat radiation to space – hence global cooling
- Significantly increased terrestrial Albedo
- Reduction in atmospheric water vapour levels as precipitation enters the groundwater and eventually the sea – reduction in the most important greenhouse gas

Why Won't it Run Away?

The humidity of the surrounding field would be kept below the critical level at which the vortex would be self-sustaining. Only after passing geothermal hot water/steam through the vortex engine heat exchangers would the energy level become super-critical. The air temperature would be in the region of 40 – 50 Celsius above ambient.

The “boundary layer fence” would act to quarantine the vortex from the surrounding boundary layer, except for allowing the flow of air through the control dampers and turbines.

The most **ideal** location for the vortex engine would be near the Equator (the intertropical convergence zone) where wind is relatively infrequent.

Thermals

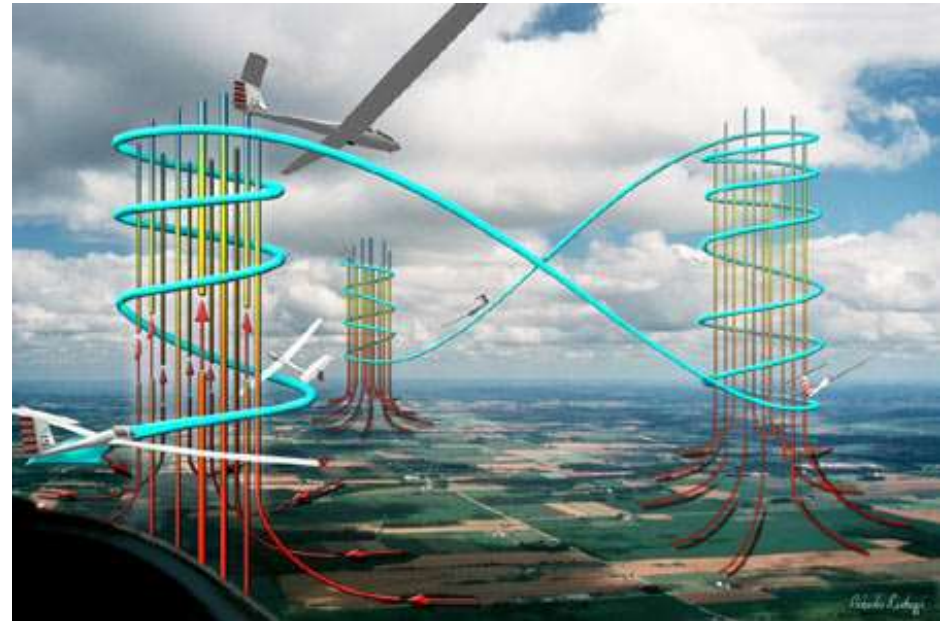
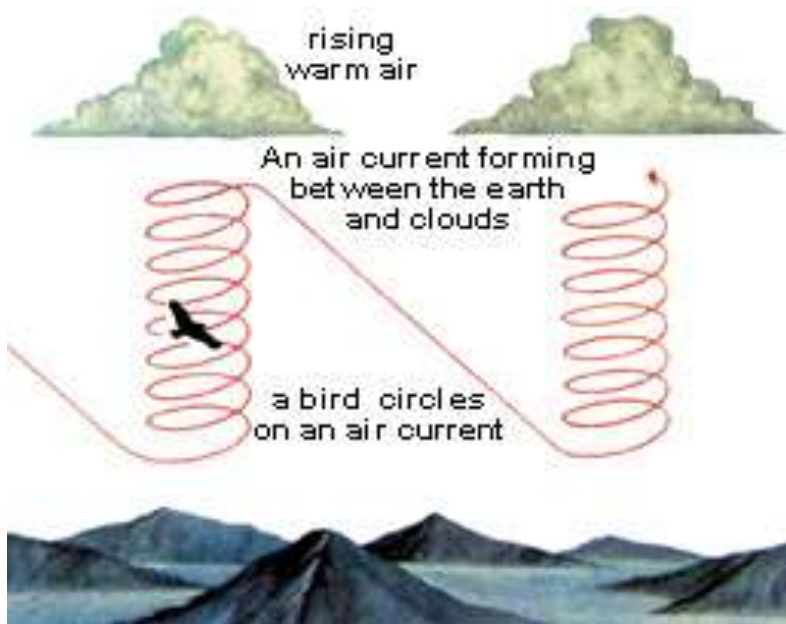

Birds have been extracting energy from thermal updrafts for millions of years. Glider pilots have been copying them for about eighty years and we take this for granted. With some not particularly high-tech engineering, much higher energy can be extracted via vortex engines. It is envisaged that the vortex engines would be interconnected within a power grid. If high cross winds were experienced in one area, local generators would be closed down and power imported from another part of the grid.

There are also very large areas of the Earth's surface (particularly the intertropical convergence zone, or doldrums) where winds are always negligible or low.

The Stability of Thermals

Thermal updrafts associated within heat sources are stable in terms of both **space** and **time**.

Crosswinds act to reduce the strength of the updraft by causing turbulent mixing with the surrounding atmosphere.

There is no reason to believe that the updraft plume from the vortex engine would be any different.

What Sort of Power Will Be Produced?

Based on a total power similar to an average tornado (1 GW expended) and an overall system efficiency of around, say, 20%, a power output of 200 MW could be expected per engine.

For the GaTech proposal, each 10m module is projected to produce 50kW.

What will it Cost?

Based on extrapolation from dry cooling tower costs, a 200 MWe plant could be expected to cost in the order of \$500 million. There are many unknowns at this stage, but this estimate is probably conservatively high.

This would compare favourably with that for Enviromission's 200 MWe solar power tower prototype, which is expected to cost in the region of \$750 million, or a conventional geothermal power station of the same output which would cost around \$800 million, before power transmission costs were factored in.

Won't large numbers of Vortex Engines disrupt normal atmospheric circulation?

The Vortex Engine can be arranged to have either clockwise or anticlockwise rotation:

“Tornadoes normally rotate cyclonically (when viewed from above, this is counterclockwise in the northern hemisphere and clockwise in the southern). While large-scale storms always rotate cyclonically due to the Coriolis effect, thunderstorms and tornadoes are so small that the direct influence of the Coriolis effect is unimportant, as indicated by their large Rossby numbers...”

Wikipedia

Where Would It Work Best?

Regions

- Tropical regions with good geothermal resources such as Indonesia, Bangladesh and the Philippines and high CAPE (convective available potential energy) – the inter tropical convergence zone
- Arid or semi-arid regions such as Australia, the Arabian Peninsula, Turkey, Palestine and southern and northern Africa
- Along arid regions with good geothermal resources such as Afghanistan, Tibet, northern India, Pakistan, Jordan, Ethiopia and Nepal
- South western USA and northern Mexico
- Offshore north-western Europe - Britain and the Netherlands reportedly have the highest frequency of tornadoes per unit area on Earth, although of relatively low intensity
- Offshore China and Japan (geothermal resources and high CAPE)

Ideal Conditions

- Low crosswinds
- High CAPE (convective available potential energy)
- Geothermal energy availability
- Currently arid or semi arid (to make use of enhanced precipitation)

“Stuck in the Doldrums” – the Intertropical Convergence Zone (ITCZ)



“The Intertropical Convergence Zone, is the region that circles the Earth, near the equator, where the trade winds of the Northern and Southern Hemispheres come together. The water in the equator is warmed by the intense sun which in turn heats the air in the ITCZ, raising its humidity and making it buoyant.”

ITCZ - “The Doldrums” – perfect for the vortex engine

“Aided by the convergence of the trade winds, the buoyant air rises. As the air rises it expands and cools, releasing the accumulated moisture in an almost perpetual series of thunderstorms.”

The Dreaded Belt of Calm

“Early sailors named this belt of calm “the Doldrums” because of the inactivity and stagnation they found themselves in after days of no wind. In an era when wind was the only effective way to propel ships across the ocean, finding yourself in the Doldrums could mean death...”

<https://blog.mytimezero.com/2014/01/10/stuck-in-the-doldrums-the-intertropical-convergence-zone/>

This combination of high Convective Available Potential Energy (CAPE) and low crosswind is ideal for the operation of the vortex engine.

The Asian Brown Cloud

“The Asian brown cloud is created by a range of airborne particles and pollutants from combustion (e.g., woodfires, cars, and factories), biomass burning and industrial processes with incomplete burning. The cloud is associated with the winter monsoon (November/December to April) during which there is no rain to wash pollutants from the air.”

Wikipedia

The Asian Brown Cloud is closely associated with the Inter Tropical Convergence Zone.

The Asian Brown Cloud

Atmospheric brown clouds: Impacts on South Asian climate and hydrological cycle

- (i) Increase in aerosols can nucleate copious amounts of small droplets, which can inhibit the formation of larger raindrops and decrease precipitation efficiency (33). This microphysical effect can suppress rainfall in polluted regions (5) and add to the rainfall decreases simulated in the present study.*
- (ii) There has been a steady increase of drought frequency from the 1930s, which peaked in the 1980s (Fig. 7), with decrease in average rainfall after the 1960s. The drought frequency abated during the 1990s (30), but the decadal rainfall was still less than normal. During 2001–2004, two droughts have already occurred, and the average rainfall for this decade so far is 9% below normal. These negative trends lead us to speculate whether the ABC is indeed appearing to show its impact as guided by our modelling results, even though there may be other causes such as El Niño–Southern Oscillation–monsoon (32, 34) interactions or natural variations in other slowly varying boundary conditions such as land-surface moisture, Eurasian snow cover, and others (34).*
- (iii) ABCs have such a large effect on the monsoon primarily because the forcing simultaneously impacts many components of the monsoon system, including the solar heating of the surface–atmosphere system, the SST gradient, the convective instability of the troposphere, evaporation, and the Hadley circulation, which are factors that have fundamental influences on the monsoon rainfall (25, 30, 31, 34).*

The Atmospheric Brown Cloud

“...The increase in atmospheric stability and the reduction in rainfall are important aspects of the air pollution impacts on climate. Both these effects can enhance the lifetime of aerosols because increases in low-level inversion (see [Fig. 4](#)) can increase the persistence of brownish haze layers, and reduction in rainfall can decrease the washout of aerosols. Such feedback effects should be included in future studies to understand the full impact of the ABCs on South Asia. Of particular concern is the reduction in monsoon rainfall in India because in South Asia there is a strong positive correlation between food production and precipitation amount ([35](#)). In addition, availability of fresh water is a major issue for the future ([36](#)). Even with the forcing fixed at 1998 values, the rainfall decrease in India continues to worsen beyond 1998 ([Fig. 3B](#)). The impact of the ABC on monsoon rainfall, in conjunction with the health impacts of air pollution ([37](#)), provides a strong rationale for reducing air pollution in the developing nations.”

“However, a sudden reduction in air pollution without a concomitant reduction in global GHGs also can accelerate the warming in South Asia because, according to the present simulations, ABCs have masked as much as 50% of the surface warming due to GHGs.”

<http://www.pnas.org/content/102/15/5326.full>

Another source

“...White sulfur aerosols cool the climate; black carbon soot warms the climate. So when you mix the two kinds of aerosol pollution up in the Asian brown cloud, one would expect climate effects to even out. Unfortunately in our physical world things are never that simple.”

COOLING ON GROUND, WARMING IN AIR

“The reason the reflective (light) and absorbing (dark) aerosols in the brownish mix do not compensate each other’s effects, is that they both block sunlight - so they both lead to cooling on the surface directly beneath the haze, which is thickest over the north of India, including the Ganges Basin. As darker-coloured soot aerosols are dominant in the mix higher up in the atmosphere, energy absorption outweighs solar reflection - so the brown haze leads to net atmospheric warming.”

“When you have warm air up high and cooler temperatures on the ground, you create what meteorologists call a stable atmosphere, with suppressed convection, and little precipitation. Higher air pressure at the surface makes the brown haze block the monsoon ...”

<http://www.bitsofscience.org/indian-monsoon-climate-change-3470/>

Atmospheric Brown Cloud

- Widespread layers of brownish haze
- Regions
 - Indo Gangetic Plain in South Asia
 - East Asia
 - Indonesian Region
 - Southern Africa extending southwards
 - The Amazon basin in South America

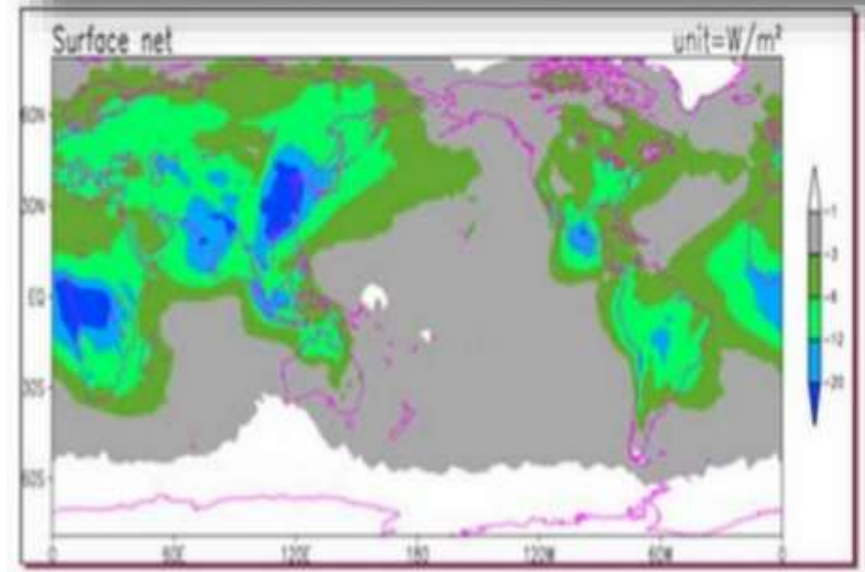
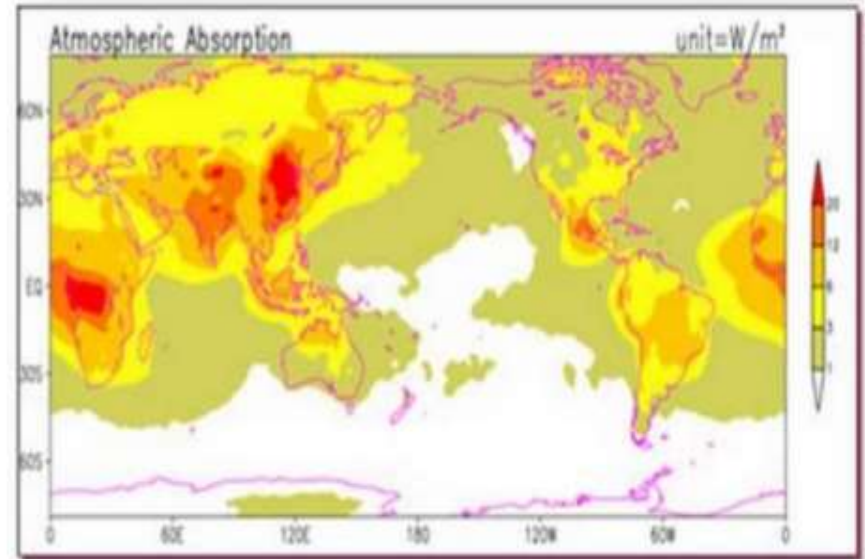

Intertropical Convergence Zone

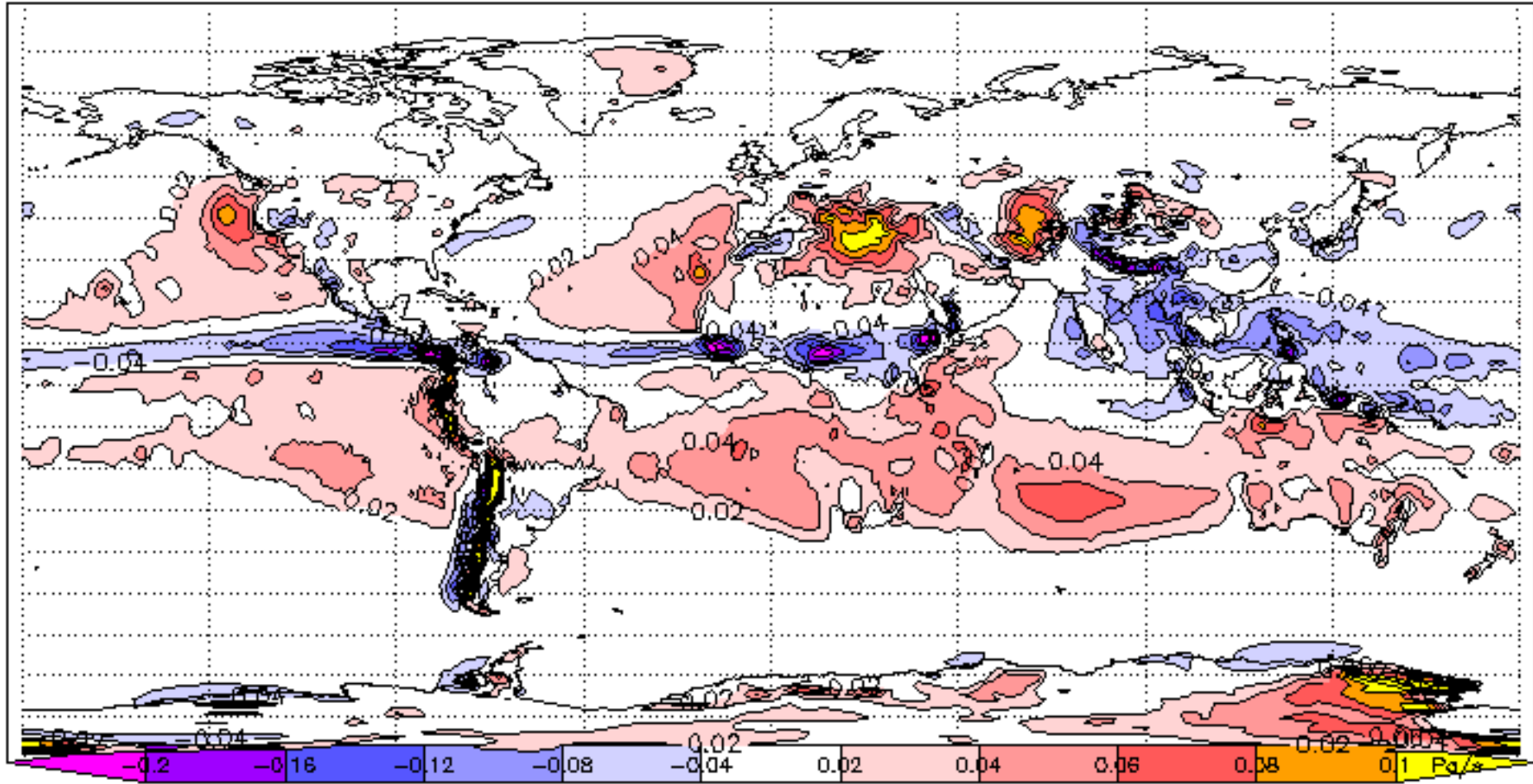

Vertical air velocity at 500 hPa, July average. Ascent (negative values) is concentrated close to the solar equator; descent (positive values) is more diffuse

https://en.wikipedia.org/wiki/Intertropical_Convergence_Zone#/media/File:Omega-500-july-era40-1979.png

a

Tropical Tropopause Layer and Deep Convection

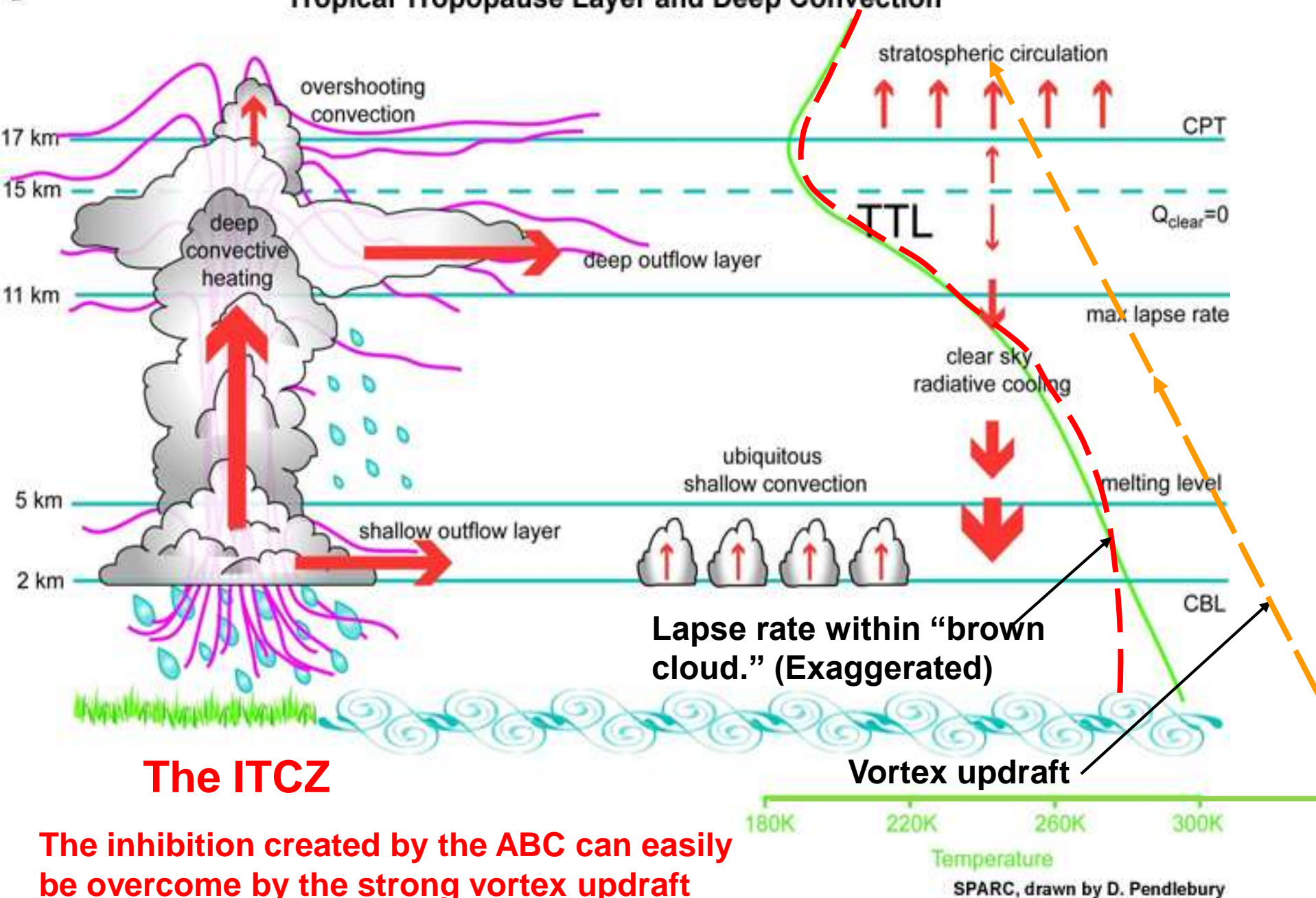

The ITCZ

The inhibition created by the ABC can easily be overcome by the strong vortex updraft

Idealized Tropospheric Circulation

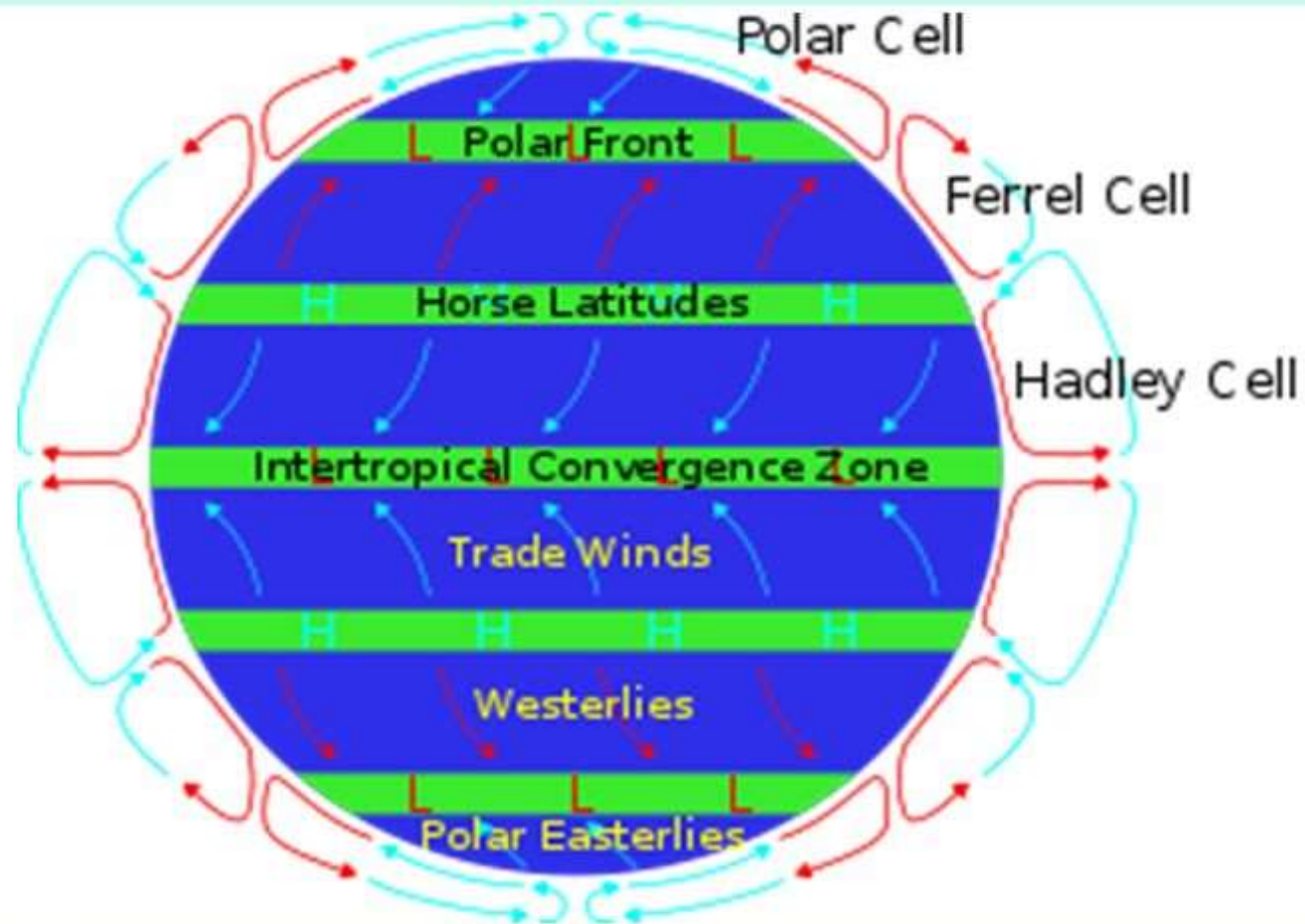

ITCZ & Polar Front Storm Belts – Hi Precipitation
Horse Latitude & Polar Deserts

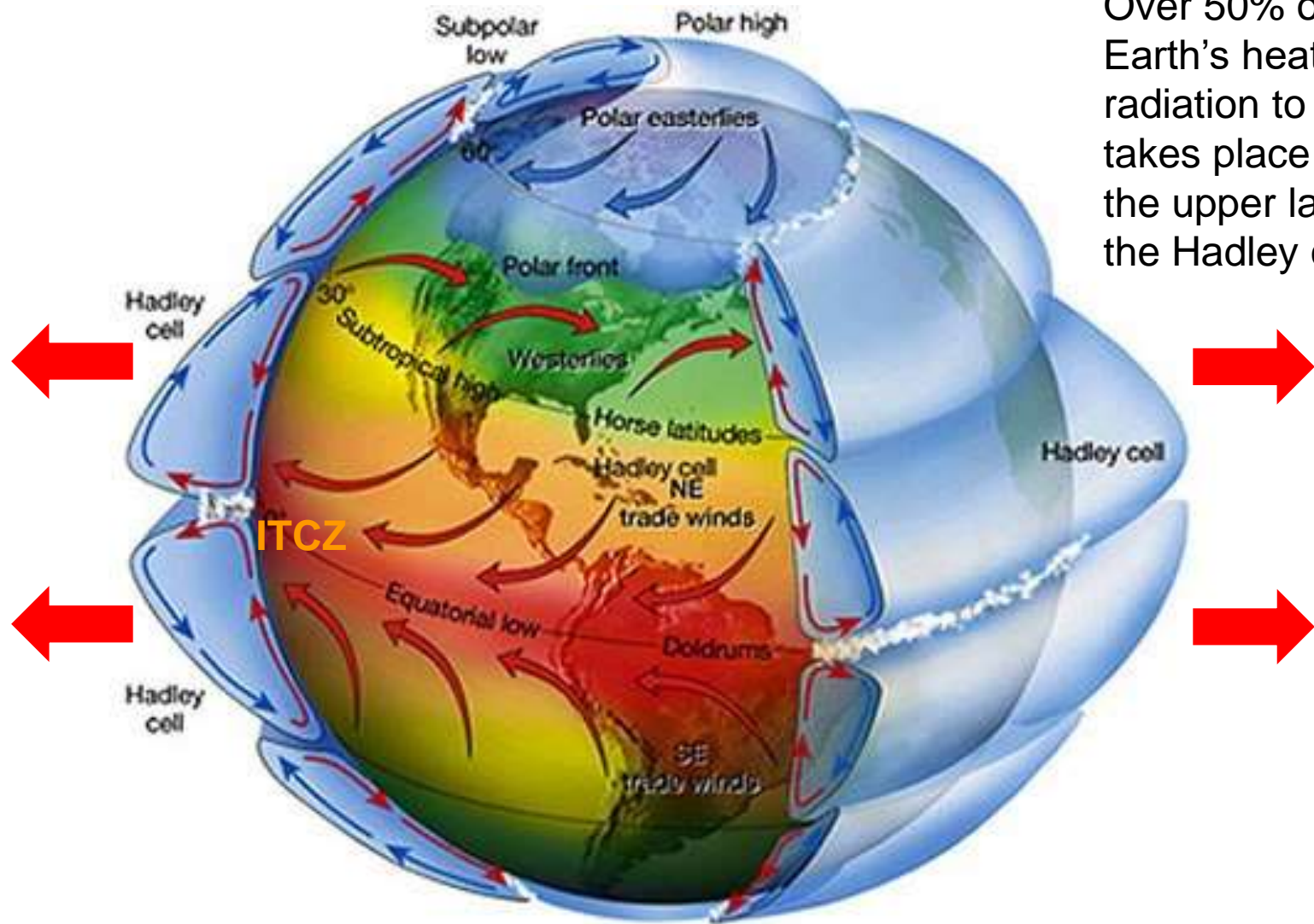

Over 50% of Earth's heat radiation to Space takes place from the upper layers of the Hadley cell

Efficient operation of the Hadley cell is crucial for Earth's heat budget!

Asian Summer Monsoons

Division of Asia-Pacific Monsoon

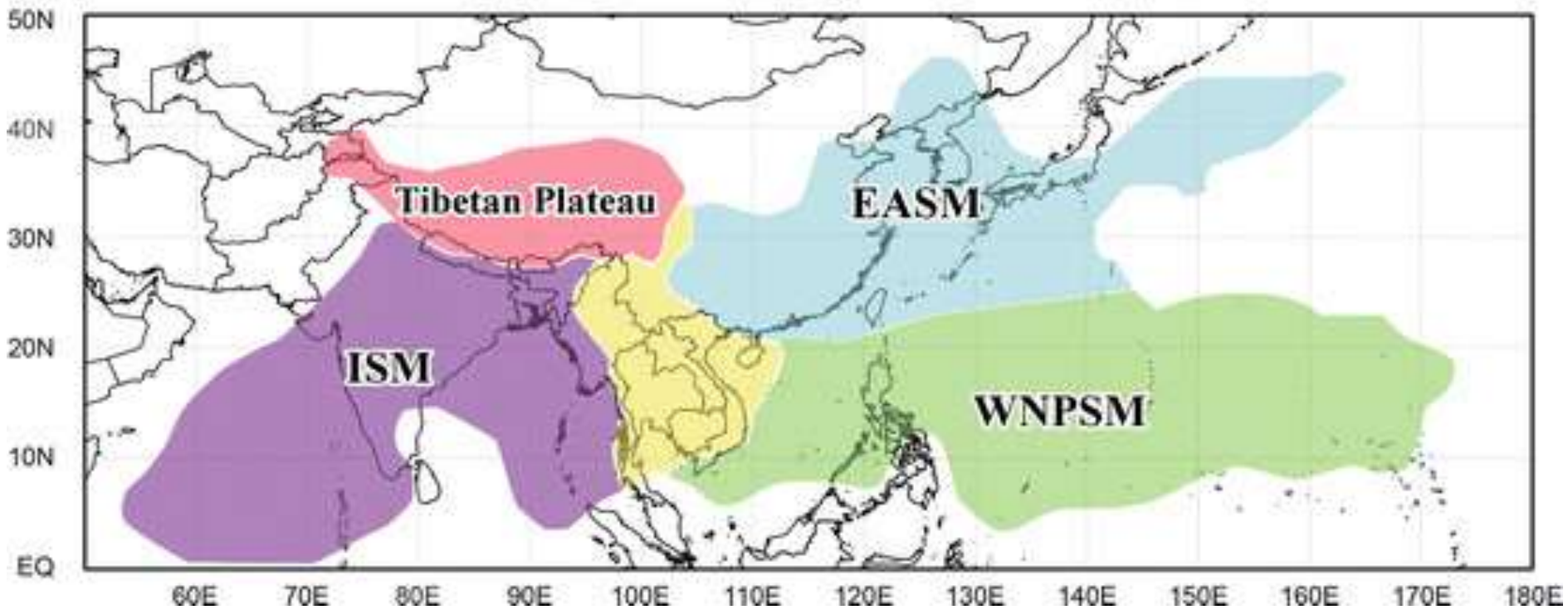

East Asian Summer Monsoon is weakening

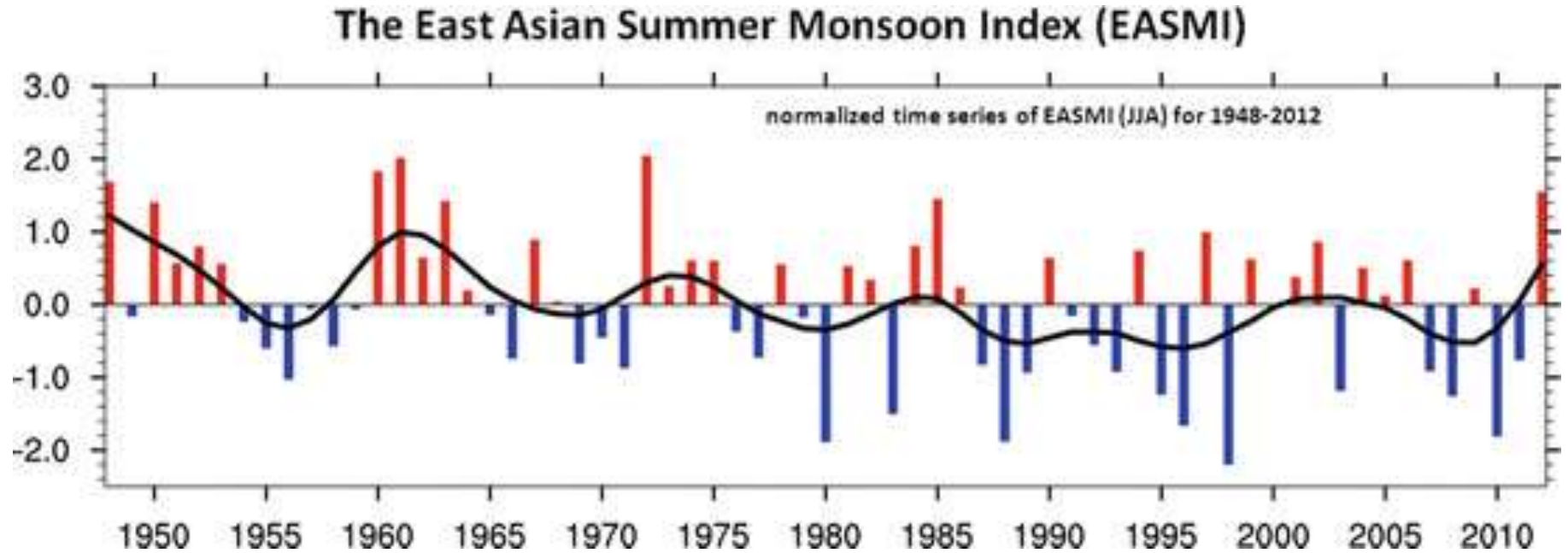

The north of China gets 60 – 70% of its precipitation from the monsoon

Global Monsoons are weakening

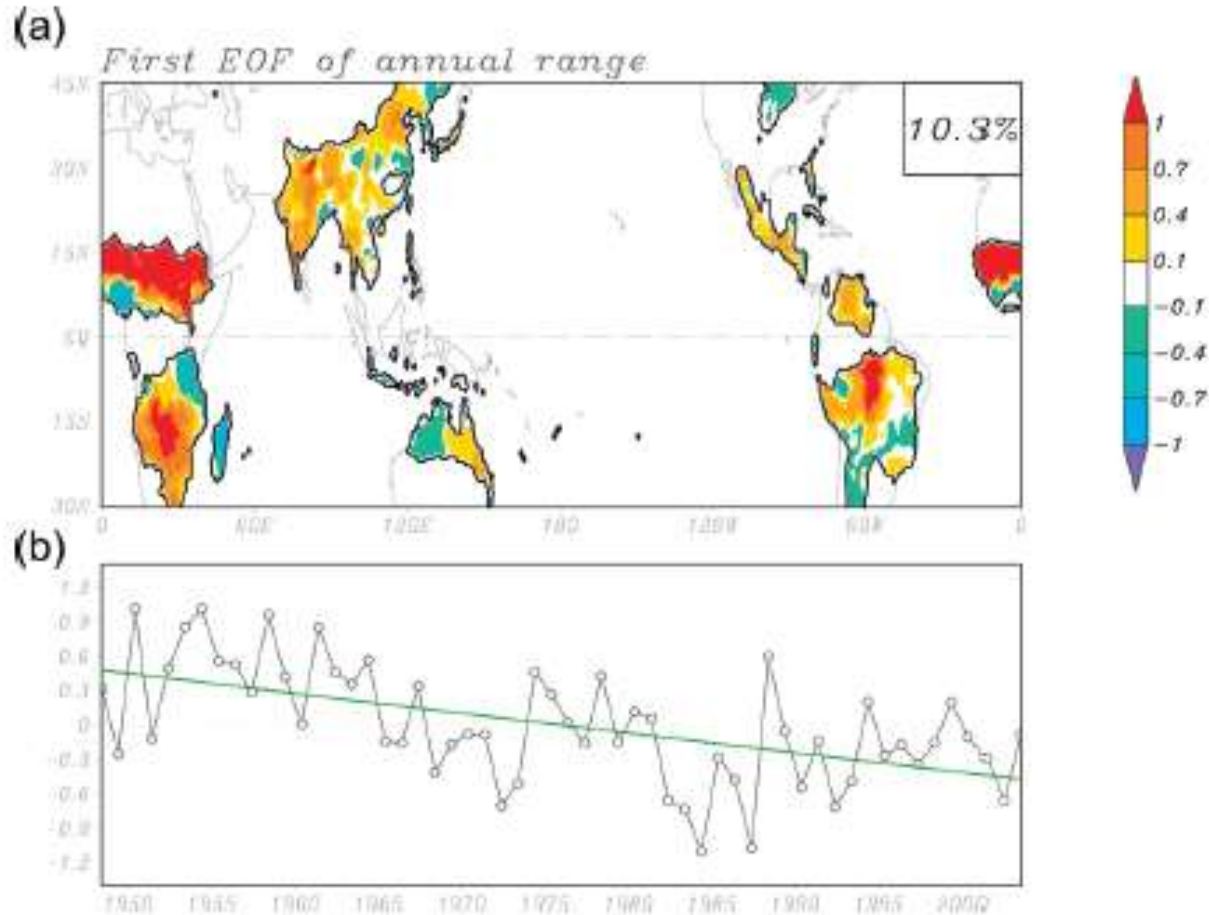

Figure 3. (a) The spatial pattern of the leading Empirical Orthogonal Function (EOF) mode of the normalized annual range anomalies over the global continental monsoon regions; (b) the corresponding principle component or annual range index (ARI). The bold contour indicates the boundaries of the monsoon domain.

China's water supply

...China's disadvantage, compared with the United States, is that it has a smaller water supply yet almost five times as many people. China has about 7 percent of the world's water resources and roughly 20 percent of its population. It also has a severe regional water imbalance, with about four-fifths of the water supply in the south...

Tough political choices... seem unavoidable. Studies by different scientists have concluded that the rising water demands in the North China Plain make it unfeasible for farmers to continue planting a winter crop.

China's water supply

...[If] China became an ever bigger customer on world grain markets... grain prices could steadily rise, contributing to inflation and making it harder for other developing countries to buy food.

The social implications would also be significant inside China. Near Shijiazhuang... [farms] depend on wells that are more than [200 metres] deep. Not planting winter wheat would amount to economic suicide.

<http://www.nytimes.com/2007/09/28/world/asia/28water.html>

Where would the system best be located?



Sedimentary aquifer geothermal resources

Sedimentary basins of the world

Source: modified from www.glossary.oilfield.slb.com/DisplayImage.cfm?ID=15

<http://www.curtin.edu.au/research/cusp/local/docs/geothermal-oldmeadow-marinova.pdf>

Hot sedimentary aquifer example

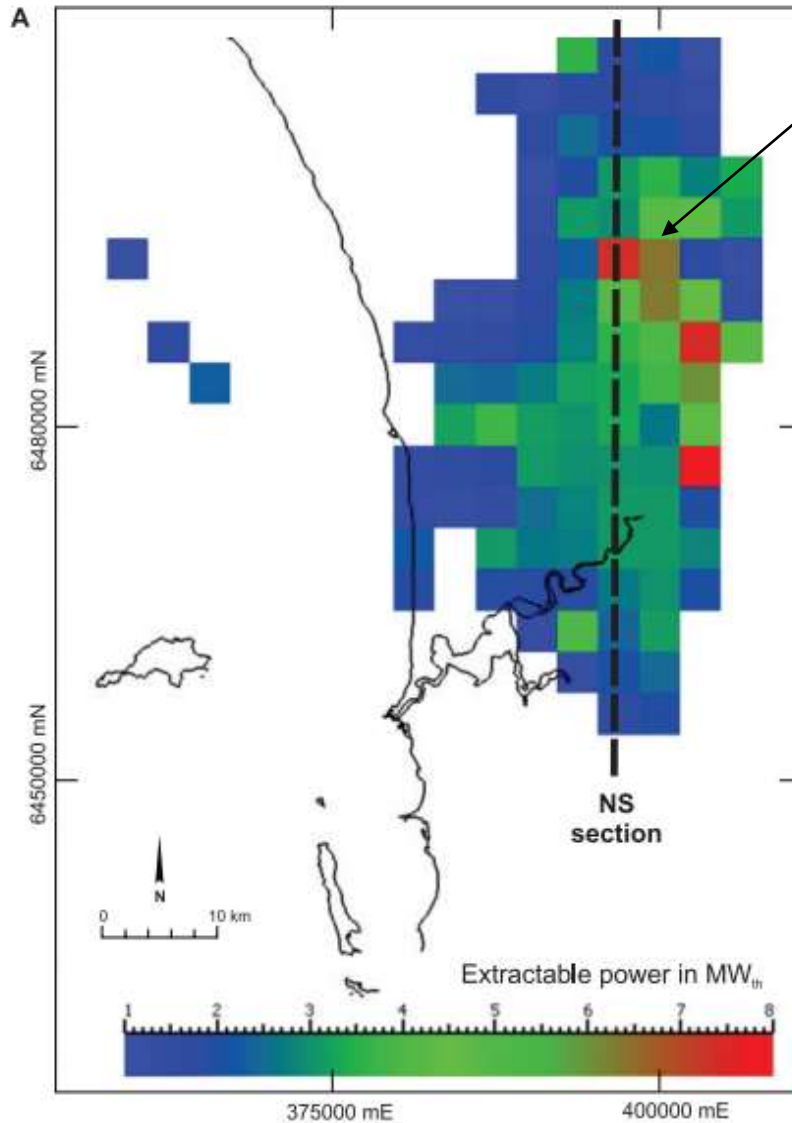

Gnamptara mound north of Perth, Western Australia

Figure 3.7: (a) Map view of summed reservoirs above 1 MW_{th} potentially fulfilling the parameters we defined for absorption chiller applications. Areas with reservoirs producing less than 1 MW_{th} are left white. The colour map shows the extractable thermal power.

Total sustainable yield approximately 200 MW_{th}

How high would the vortex need to be?

- For maximum precipitation, the top of the vortex should be towards the top of the troposphere (ref Emanuel chart slide 23)
- As the Carnot efficiency is a function of temperature differential, again, higher altitudes will give higher efficiencies
- In general, the system should aim to achieve altitudes above about five kilometres. The solar updraft tower with a one kilometre high stack can only achieve an efficiency in the order of 3%

The Carnot Potential Wind Speed

Map showing the maximum wind speed in MPH achievable by tropical cyclones over the course of an average year according to Carnot's theory of heat engines.

Source: *Divine Wind* by MIT Professor Kerry Emanuel

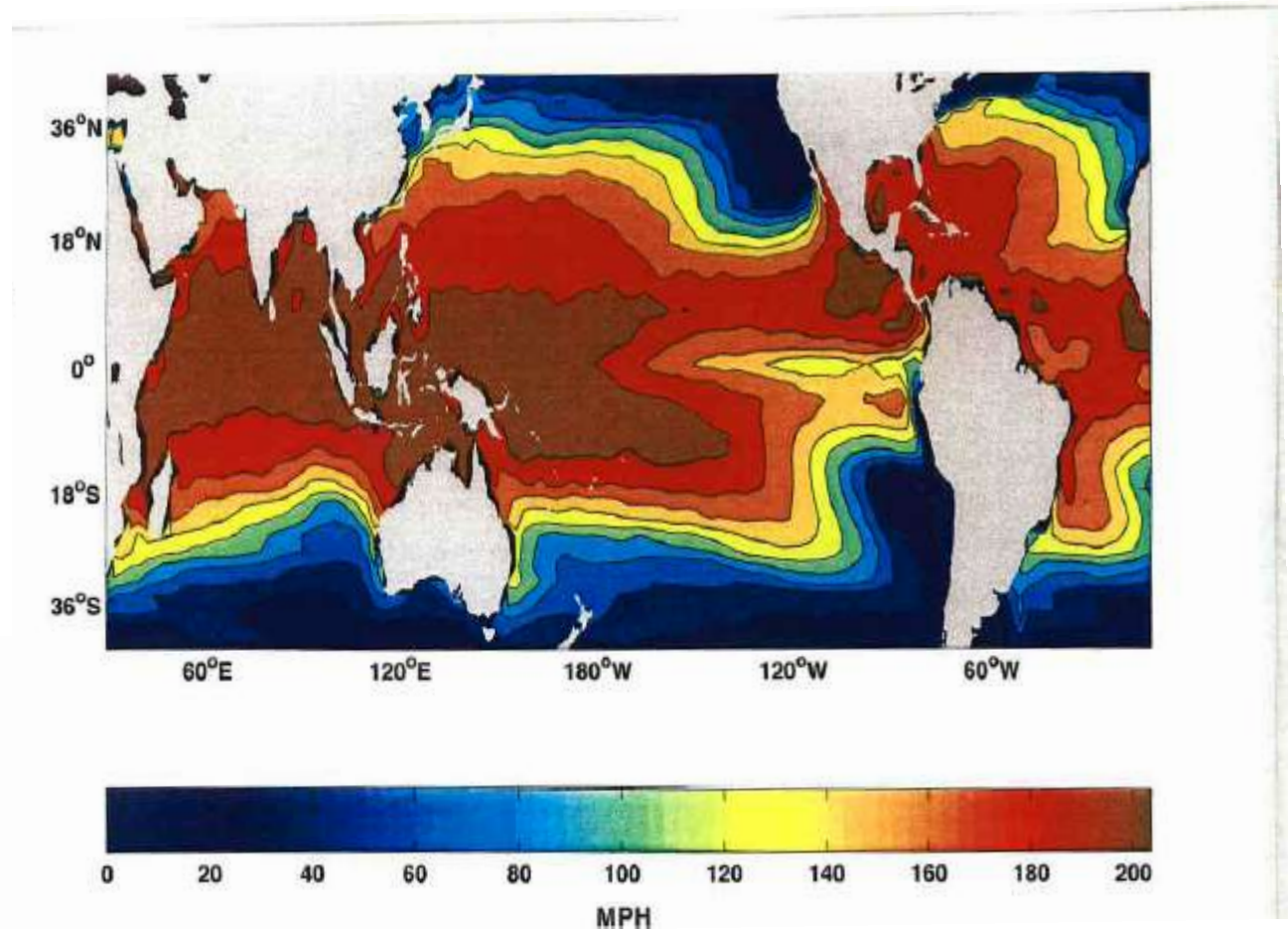

How can a small-scale prototype be built?

The prototype should arguably be energised by the following:

- Utilisation of waste gases from industrial processes, particularly those containing high water vapour content
- Injection of high velocity gases into a vortex chamber

This would facilitate demonstration of the principle of the updraft vortex, while eliminating the need for a relatively expensive heat exchange system.

Sketch of "20 metre" prototype

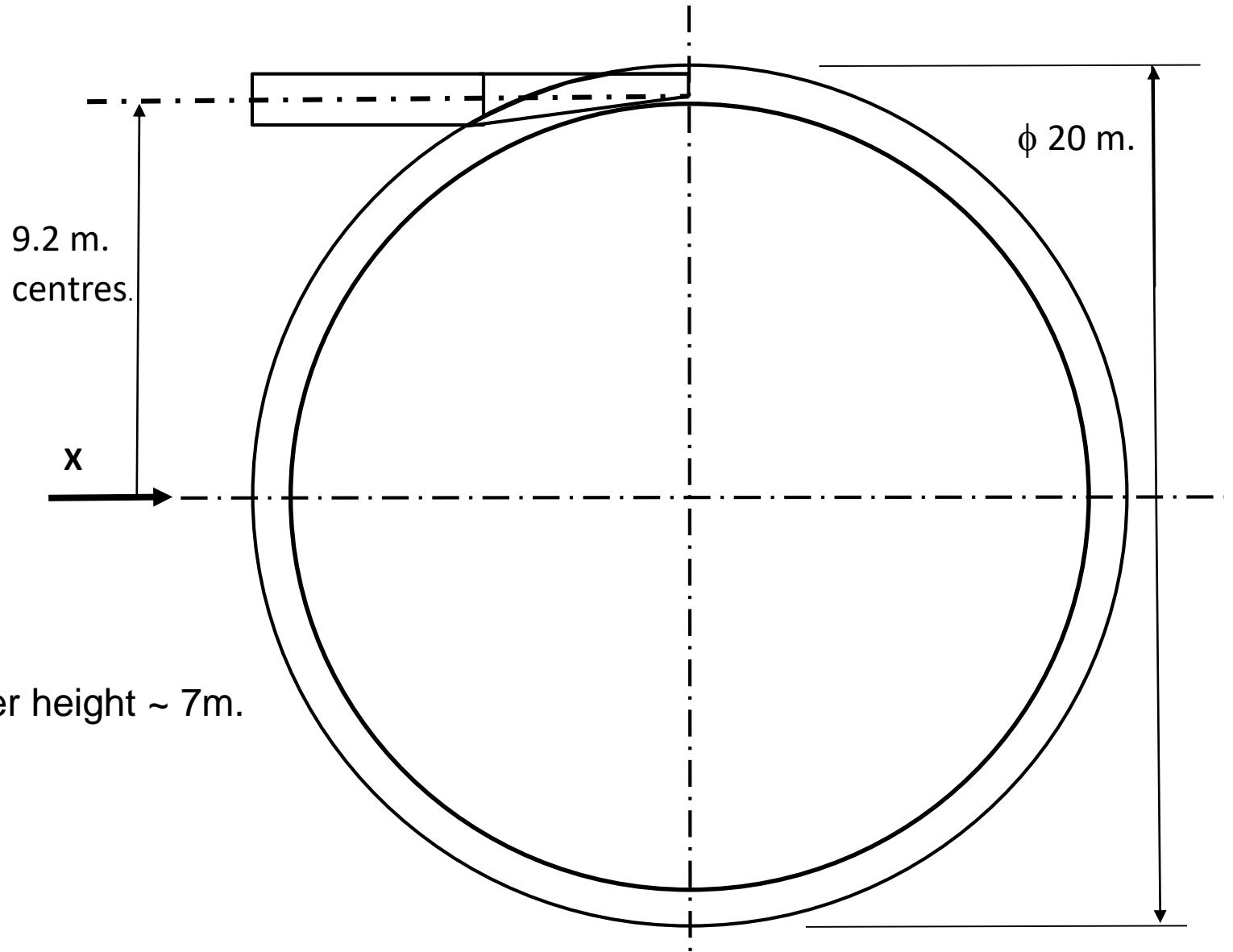

Sketch of 20 metre prototype

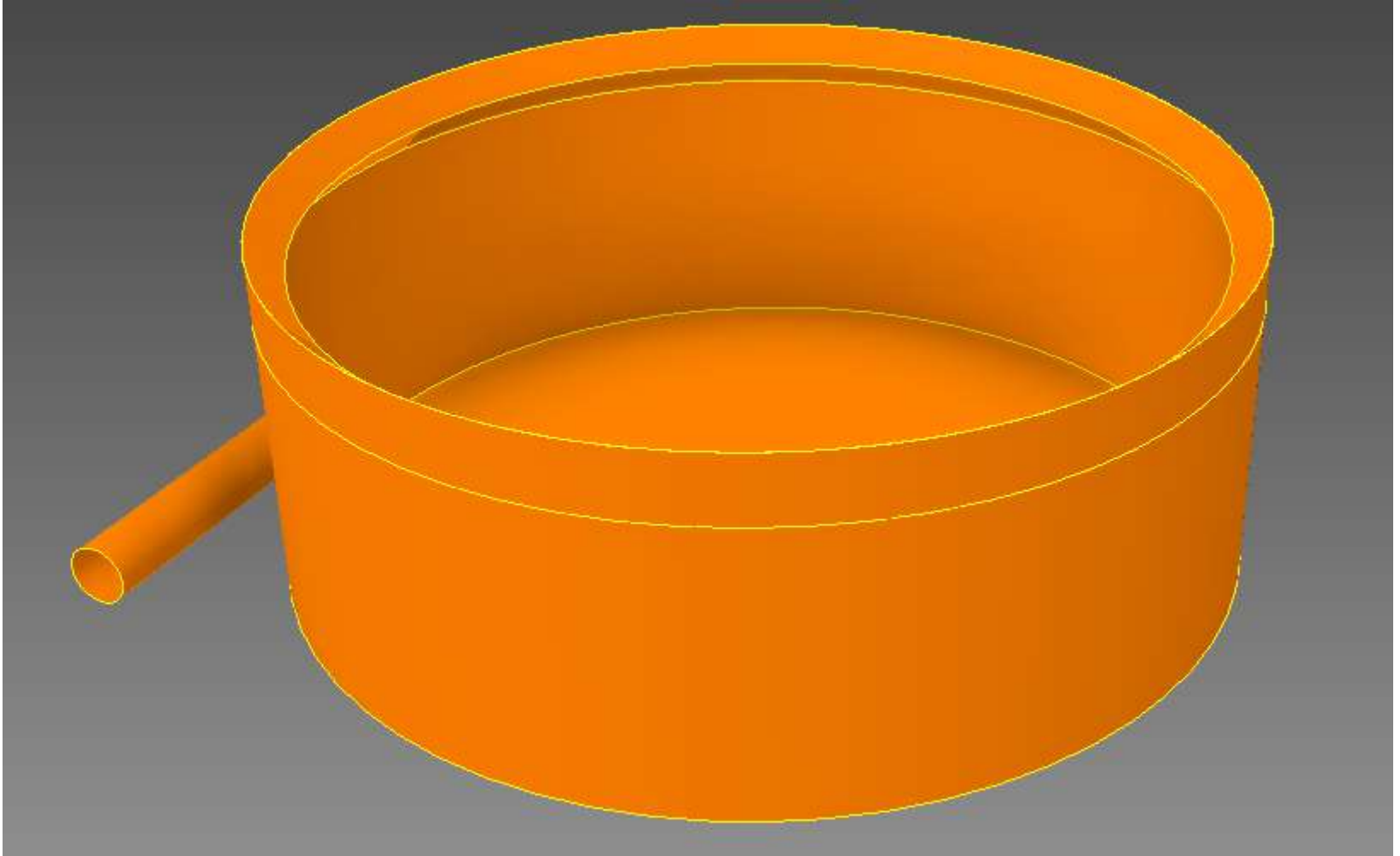

Proposed Exemplar

A particular waste gas on the downstream side of a wet scrubber in an extractive metallurgical plant in the writer's experience had the following characteristics:

– Temperature	82°C
– Water vapour content	~22%/w
– CO ₂	10%
– Exit velocity from induced draft fan	40 m/s
– Approximate volumetric flow rate	40 m ³ /s
– Approximate energy flux	25 MW
– Gas stream fluid power	500 kW

This would be ideal for use as feedstock for a 20 metre diameter vortex engine prototype.

The prototype would primarily be useful to demonstrate the feasibility of dispersal of waste gases from process and power plant stacks with power generation as a bonus.

Prototype projected cost

The cost of such a prototype would vary considerably with the location in which it was built.

A rough estimate for China would be in the region of around US\$1 million dollars, assuming that the heat input for, say, a year's research comes free of charge in the form of waste vapour and gas, and that the fan is available from existing plant.

Vortex Engine: General Conclusion

The increasing severity of tropical cyclones and tornadoes in some regions is arguably a pointer to Earth's need to dump heat to Space.

That's fine, but we need to learn to control the location, frequency and intensity of the process... hence the need for vortex engine research

Climate Change

The following text is extracted from MIT Professor Kerry Emanuel's book "**What We Know About Climate Change**," published in 2007. It appears to be apposite to the current situation:

- *The global mean temperature is now greater than at any time in at least the past 500 to 1,000 years...*
- *Rainfall will continue to become concentrated in increasingly heavy but less frequent events.*
- *The incidence, intensity, and duration of both floods and drought will increase.*
- *The intensity of hurricanes will continue to increase, though their frequency may dwindle.*

All these projections depend, of course, on how much greenhouse gas is added to the atmosphere over the next century, and even if we could be certain about the changes, estimating their net effect on humanity is an enormously complex undertaking, pitting uncertain estimates of costs and benefits against the costs of curtailing greenhouse-gas emissions. But we are by no means certain about what kind of changes are in store, and we must be wary of climate surprises.

Even if we believed that the projected climate changes would be mostly beneficial, we might be inclined to make sacrifices as an insurance policy against potentially harmful surprises.

Harnessing the vortex principle will not be easy, and the risks are significant.

On the other hand there is a strong argument that research **must be carried out to determine its viability:**

“[Global warming is] perhaps the most consequential problem ever confronted by Mankind. Like it or not, we have been handed Phaeton’s reins, and we will have to learn how to control climate if we are to avoid his fate.”

Professor Kerry Emanuel

End